

Table of Contents

2.0	Table of Contents
2.1	System description
2.100	System description (general)
2.105	System description (data)
2.115	COOLMANT range, Ø 125 - Ø 315 / SDR 11/SDR 17 (bars)
2.2	Planning, design engineering
2.200	Pressure loss chart for water, Ø 125 - Ø 315 / SDR 11
2.201	Pressure loss chart for ethylene glycol, Ø 125 - Ø 315 / SDR 11
2.202	Pressure loss chart for water, Ø 125 - Ø 315 / SDR 17
2.203	Pressure loss chart for ethylene glycol, Ø 125 - Ø 315 / SDR 17
2.210	Heat losses
2.3	Components
2.300	House entry bend, 90°
2.320	Joint (PE-HD shrink sleeve), dimension Ø 225 - 450 mm
2.340	T-piece, angled at 45°, dimension Ø 125 - 315 mm / SDR 11/ SDR 17
2.345	Insulation material
2.359	PE jointing methods, fusion welded
2.360	PE jointing methods, alternative connections
2.365	End closure, shrink-type closure, end cap (LD-PE)
2.370	Wall sealing ring for wall openings
2.375	Building entry, wall opening
2.380	Building entry, core bores/cement pipe liners
2.5	Underground construction, installation
2.500	Pipe routing
2.505	Trench dimensions
2.510	Open installation

System description

1. General

COOLMANT is the registered trade name for a rigid pipe system from Brugg Pipe Systems with carrier pipes made of polyethylene. This pipe system is especially suitable for use in local and district cooling networks, in industrial and with restrictions also for combined heat pump systems (cooling and heating).

The COOLMANT district cooling pipe has a carrier pipe produced from high-density polyethylene (PE100) as per standard EN 12162. The polyethylene pressure pipes are the standard for drinking water and waste water systems, and also for the gas supply sector. The pipes are joined by means of standard screwed connectors, mechanical pipe couplings, with normal commercial electro fusion fittings or by means of butt fusion welding technology.

The insulation is made of fine-pore CFC-free rigid polyurethane foam and, together with the medium pipe, it forms a compact composite system with excellent insulation properties. The outer casing meets the requirements for plastic casing pipes as per EN 253, ensuring that the district cooling pipe is reliably protected against mechanical influences and the possibility that water could penetrate the system. The pipes can therefore be installed at outdoor temperatures down to 0°C.

In combination with the flexible COOLFLEX district cooling system, these features make it possible to implement applications involving widely varying requirements imposed by the terrain – so the installation outlay is substantially reduced.

2. Range of applications

Max. continuous operating temperature T_{Bmax} : -20 to +40 °C*
Max. permitted operating pressure p: max. 16 bar

*warm water application with limited lifetime and operating pressure (as per DIN 8074)

System description

1. Medium pipe

Material: Polyethylene class PE100 with high density, to DIN EN 12201/DIN 8074/DIN 8075

Life expectancy: 50 years at 20 °C (16 bar) or 40 °C (11.6 bar) as per DIN 8074 (SF 1.25)

Properties: suitable as district cooling, cold water and waste water pipe

PE carrier pipe	Reference temperature	Value	Test standard
Density	–	952 - 960 kg/m ³	DIN 53479
Thermal conductivity	40 °C	0.40 W/mK	DIN 52612
Tensile strengts	20 °C	32 N/mm ²	DIN 53455
Modulus of elasticity	20 °C	1000 N/mm ²	DIN 53457
Linear expansion coefficient	20 °C	1.8 · 10 E-4 1/K	DIN 52328
Crystallite melting range	–	130 - 135 °C	–

2. Thermal insulation

Material: CFC-free, 100 % CO₂-blown polyurethane foam (PUR)

PUR insulation	Reference temperature	Rigid pipes Ø 125 - Ø 315	Test standard
Density	–	> 60 kg/m ³	ISO 845
Thermal conductivity	30	≤ 0.024 W/mK	EN 253 and ISO 8497
Percentage of closed cells	–	≥ 90 %	–
Water absorption after 24 hours	–	≤ 10 %	EN 253

3. Protective casing

Material: Polyethylene class PE 100 with high density

Purpose: mechanical protection and moisture resistance

PE protective casing	Reference temperature	Rigid pipes	Test standard
Density	–	956 kg/m ³	ISO 1133
Thermal conductivity	–	0.40 W/mK	DIN 52612
Tensile strengts	–	≥ 19 N/mm ²	DIN EN 253

COOLMANT range

Ø 125 - 315 mm / SDR 11/SDR 17 (bars)

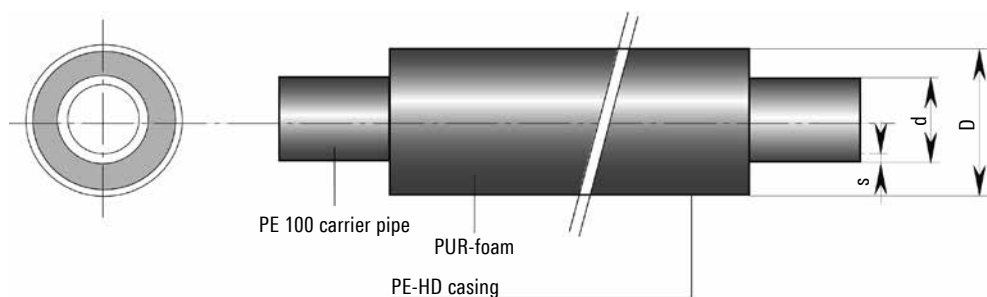

Dimensions Ø 125 - 315 mm / SDR 11

Type	Inches	PE inner pipe d x s mm	Outer casing D x s1 mm	Volume Inner pipe l/m	Weight kg/m	Standard length m
125/225	5	125 x 11.4	225 x 3.5	8.203	7.61	6/12
140/225	-	140 x 12.7	225 x 3.5	10.315	8.38	6/12
160/250	6	160 x 14.6	250 x 3.9	13.437	10.67	6/12
180/280	7	180 x 16.4	280 x 4.4	17.018	13.45	6/12
200/315	8	200 x 18.2	315 x 4.9	21.021	16.77	6/12
225/315	9	225 x 20.5	315 x 4.9	26.590	18.91	6/12
250/355	10	250 x 22.7	355 x 5.6	32.878	23.68	6/12
280/400	11	280 x 25.4	400 x 6.3	41.259	29.85	6/12
315/450	12	315 x 28.6	450 x 7.0	52.198	37.69	6/12

Dimensions Ø 125 - 315 mm / SDR 17

Type	Inches	PE inner pipe d x s mm	Outer casing D x s1 mm	Volume Inner pipe l/m	Weight kg/m	Standard length m
125/225	5	125 x 7.4	225 x 3.5	9.230	6.63	6/12
140/225	-	140 x 8.3	225 x 3.5	11.960	6.82	6/12
160/250	6	160 x 9.5	250 x 3.9	15.610	8.60	6/12
180/280	7	180 x 10.7	280 x 4.4	19.760	10.85	6/12
200/315	8	200 x 11.9	315 x 4.9	24.380	13.58	6/12
225/315	9	225 x 13.4	315 x 4.9	30.850	14.86	6/12
250/355	10	250 x 14.8	355 x 5.6	38.150	18.67	6/12
280/400	11	280 x 16.6	400 x 6.3	47.840	23.60	6/12
315/450	12	315 x 18.7	450 x 7.0	60.520	29.78	6/12

Pressure loss chart for water

Ø 125 - 315 mm / SDR 11

Water temperature 10 °C

Roughness $\epsilon = 0.01$ mm (PE100)

(1 mmWS = 9.81 Pa)

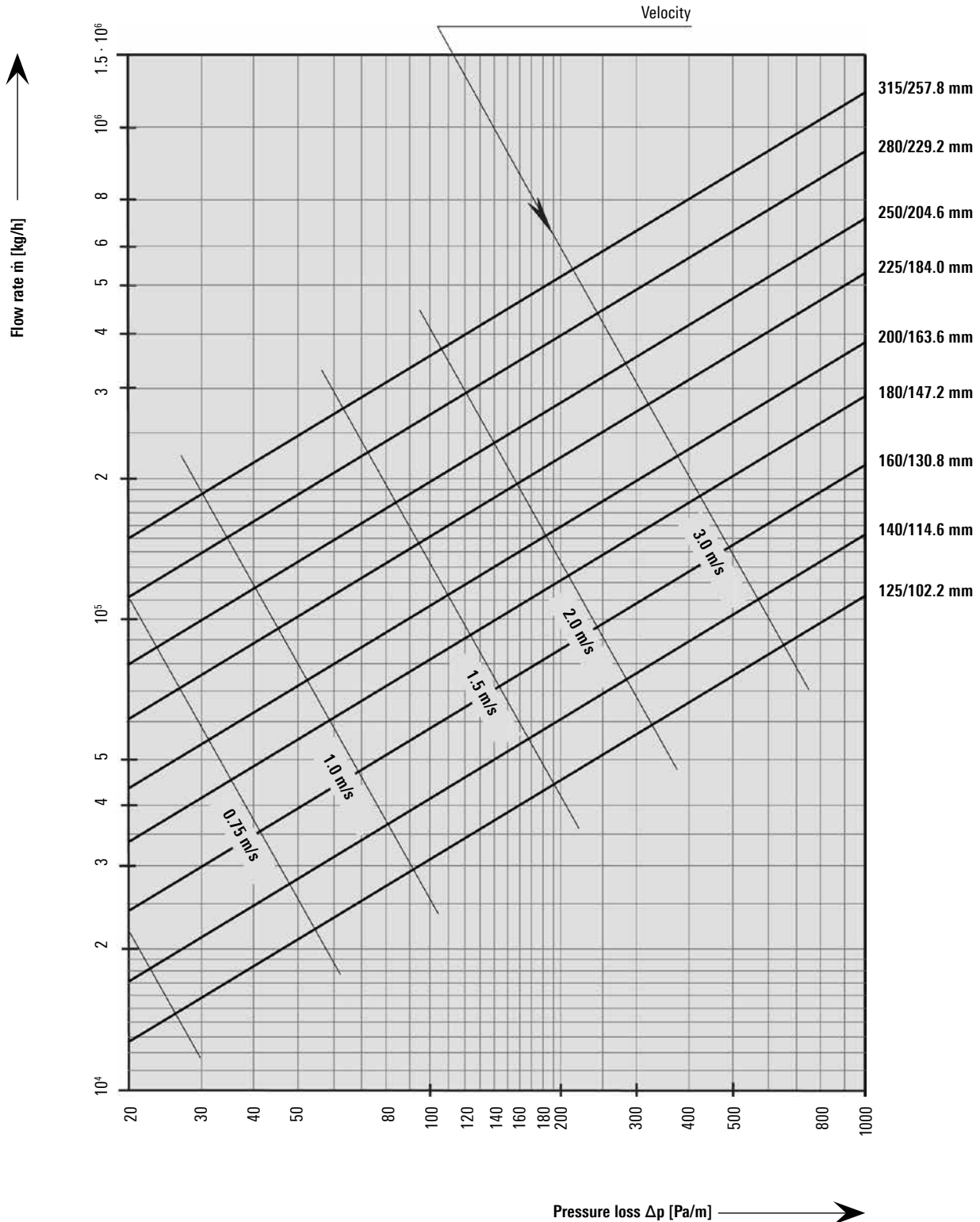

Pressure loss chart for ethylene glycol concentration

Ø 125 - 315 mm / SDR 11

Medium temperature 10 °C
Ethylene glycol 30 % concentration

Roughness $\epsilon = 0.01$ mm (PE100)
(1 mmWS = 9.81 Pa)

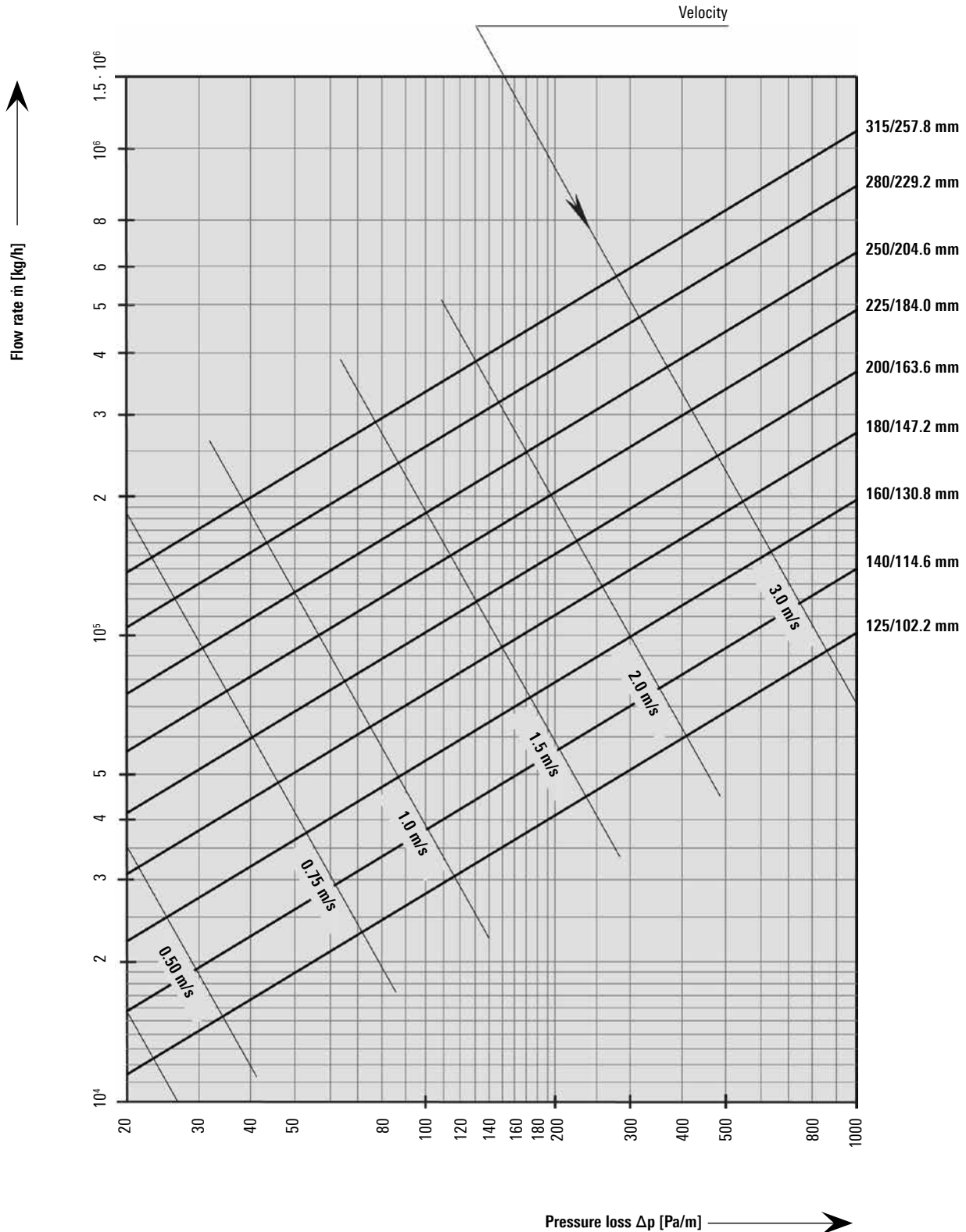

Pressure loss chart for water

Ø 125 - 315 mm / SDR 17

Water temperature 10 °C

Roughness $\epsilon = 0.01$ mm (PE100)

(1 mmWS = 9.81 Pa)

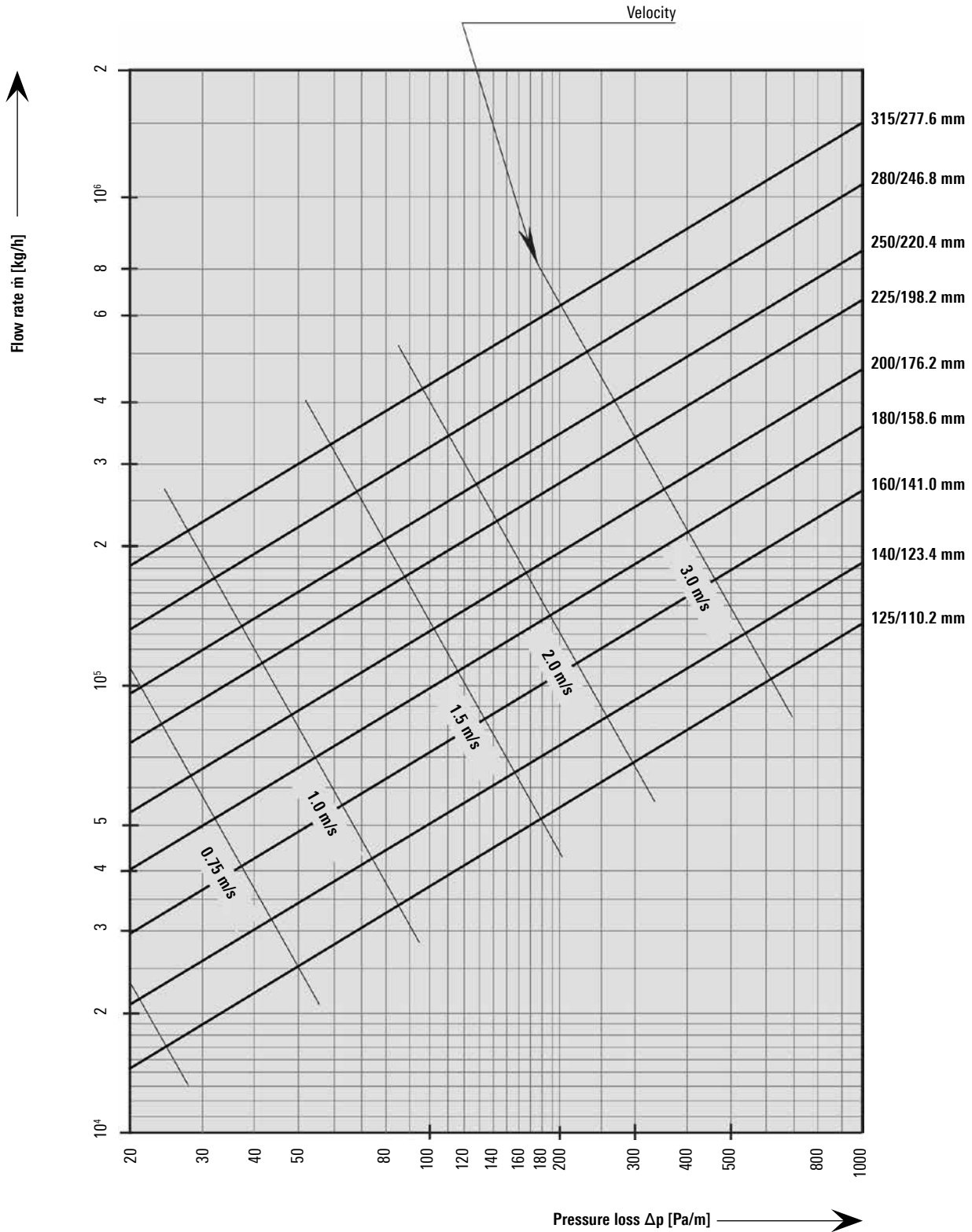

Pressure loss chart for ethylene glycol concentration

Ø 125 - 315 mm / SDR 17

Medium temperature 10 °C

Ethylene glycol 30 % concentration

Roughness $\epsilon = 0.01$ mm (PE100)

(1 mmWS = 9.81 Pa)

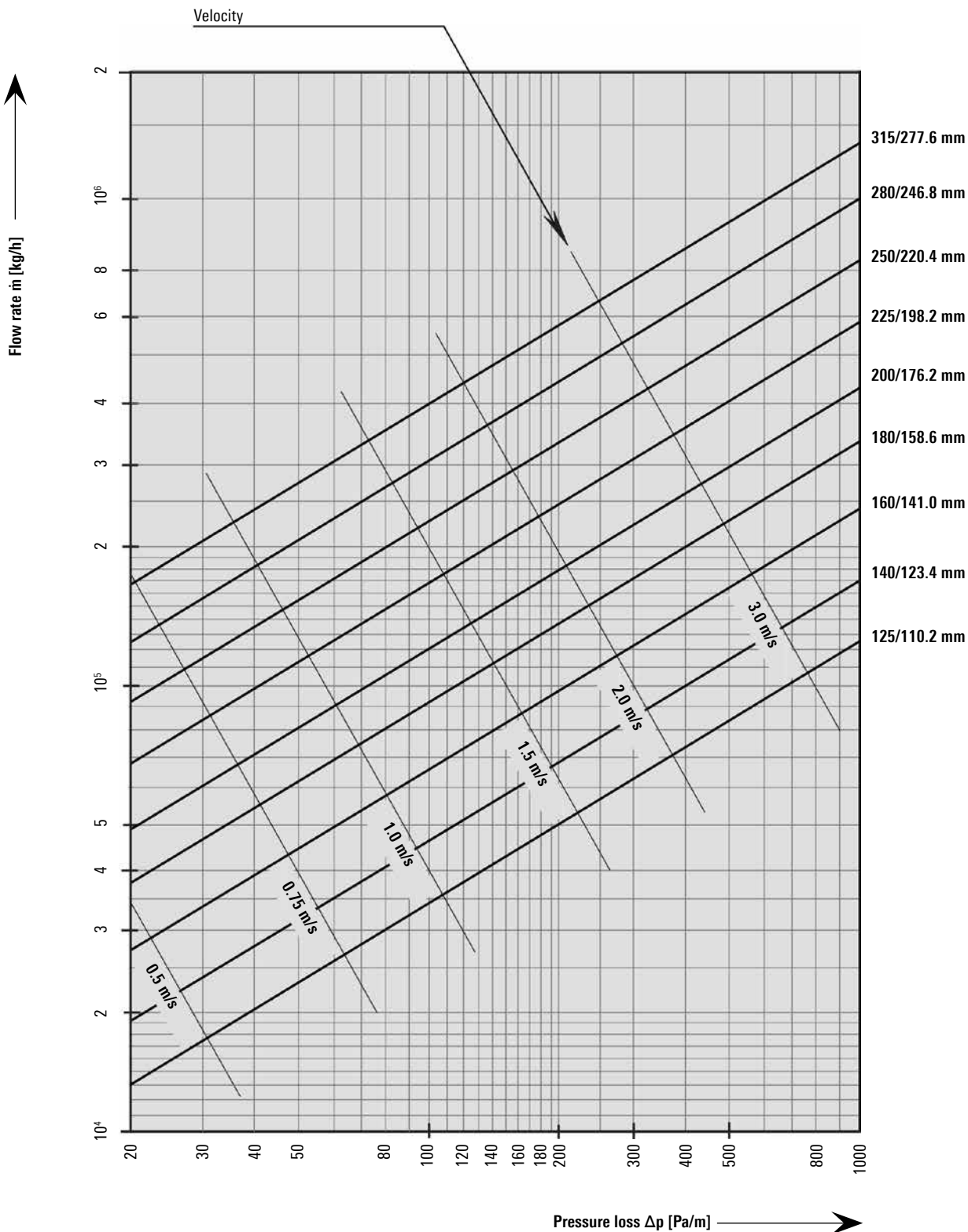

Energy losses

Applications laid in the ground

Dimensions Ø 125 - 315 mm / SDR 11

Heat losses q [W/m]						
COOLMANT	U-value [W/mK]	Average operating temperature T_B [°C]				
		6°	8°	10°	12°	14°
125/225 - SDR 11	0.233	-0.9	-0.5	0.0	0.5	0.9
140/225 - SDR 11	0.282	-1.1	-0.6	0.0	0.6	1.1
160/250 - SDR 11	0.299	-1.2	-0.6	0.0	0.6	1.2
180/280 - SDR 11	0.303	-1.2	-0.6	0.0	0.6	1.2
200/315 - SDR 11	0.296	-1.2	-0.6	0.0	0.6	1.2
225/315 - SDR 11	0.385	-1.5	-0.8	0.0	0.8	1.5
250/355 - SDR 11	0.373	-1.5	-0.7	0.0	0.7	1.5
280/400 - SDR 11	0.366	-1.5	-0.7	0.0	0.7	1.5
315/450 - SDR 11	0.370	-1.5	-0.7	0.0	0.7	1.5

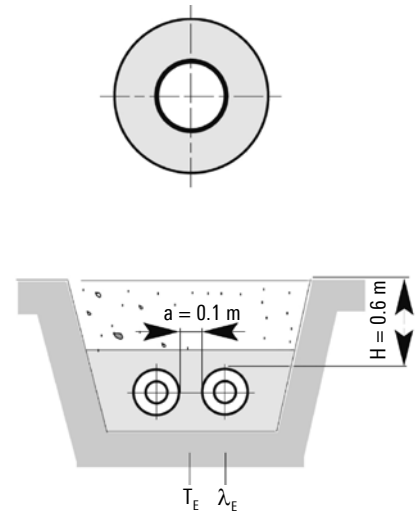

Dimensions Ø 125 - 315 mm / SDR 17

Heat losses q [W/m]						
COOLMANT	U-value [W/mK]	Average operating temperature T_B [°C]				
		6°	8°	10°	12°	14°
125/225 - SDR 17	0.234	-0.9	-0.5	0.0	0.5	0.9
140/225 - SDR 17	0.284	-1.1	-0.6	0.0	0.6	1.1
160/250 - SDR 17	0.301	-1.2	-0.6	0.0	0.6	1.2
180/280 - SDR 17	0.305	-1.2	-0.6	0.0	0.6	1.2
200/315 - SDR 17	0.299	-1.2	-0.6	0.0	0.6	1.2
225/315 - SDR 17	0.389	-1.6	-0.8	0.0	0.8	1.6
250/355 - SDR 17	0.378	-1.5	-0.8	0.0	0.8	1.5
280/400 - SDR 17	0.373	-1.5	-0.7	0.0	0.7	1.5
315/450 - SDR 17	0.374	-1.5	-0.7	0.0	0.7	1.5

Installation type CLM:	2-pipe, laid in the ground
Pipe distance:	a = 0.10 m
Covera above pipe:	H = 0.60 m
Ground temperature:	T_E = 10.00 °C
Soil conductivity:	λ_E = 1.2 W/mK
Conductivity of PUR foam:	λ_{PU} = 0.024 W/mK
Conductivity of PE pipe:	λ_{PU} = 0.40 W/mK
Conductivity of PE casing:	λ_{PU} = 0.33 W/mK

Heat loss during operation:

$$q = U (T_B - T_E) \text{ [W/m]}$$

U = Heat transfer coefficient [W/mK]

T_B = Average operating temperature [°C]

T_E = Average ground temperature [°C]

VL = Flow

RL = Return

On request, we shall be glad to calculate the heat losses for surface mounted pipe systems.

Bend, 90°

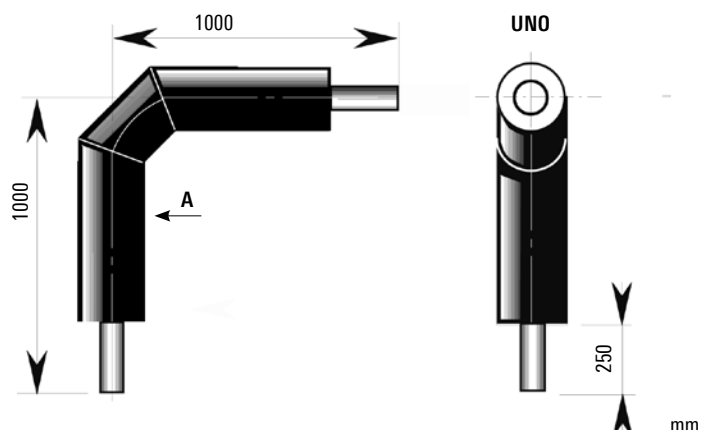

Dimensions Ø 125 - 315 mm / SDR 11

Type	Inches	PE inner pipe d x s mm	Outer pipe D x s1 mm	Volume Inner pipe l/m
125/225	5	125 x 11.4	225 x 6.9	8.203
140/225	-	140 x 12.7	225 x 6.9	10.315
160/250	6	160 x 14.6	250 x 6.2	13.437
180/280	7	180 x 16.4	280 x 6.9	17.018
200/315	8	200 x 18.2	315 x 7.7	21.021
225/315	9	225 x 20.5	315 x 7.7	26.590
250/355	10	250 x 22.7	355 x 5.6	32.878
280/400	11	280 x 25.4	400 x 6.3	41.259
315/450	12	315 x 28.6	450 x 7.0	52.198

Dimensions Ø 125 - 315 mm / SDR 17

Type	Inches	PE inner pipe d x s mm	Outer pipe D x s1 mm	Volume Inner pipe l/m
125/225	5	125 x 7.4	225 x 6.9	9.230
140/225	-	140 x 8.3	225 x 6.9	11.960
160/250	6	160 x 9.5	250 x 6.2	15.610
180/280	7	180 x 10.7	280 x 6.9	19.760
200/315	8	200 x 11.9	315 x 7.7	24.380
225/315	9	225 x 13.4	315 x 7.7	30.850
250/355	10	250 x 14.8	355 x 5.6	38.150
280/400	11	280 x 16.6	400 x 6.3	47.840
315/450	12	315 x 18.7	450 x 7.0	60.520

Joint using PE-HD shrink sleeve

Dimensions Ø 76 - 450 mm

COOLMANT joints and reduction joints

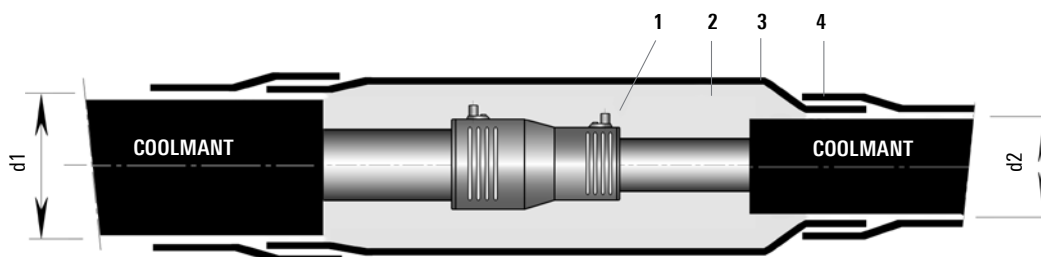

- 1 PE fusion welded joints; see CLM 2.350
- 2 Insulation material, PUR or PE; see CLM 2.345
- 3 Shrink sleeve pipe
- 4 Shrink hose

COOLMANT – COOLMANT

	Ø d2	225	250	280	315	355	400	450
Ø d1	225	x						
	250	x	x					
	280		x	x				
	315		x	x	x			
	355		x	x	x	x		
	400		x		x		x	
	450		x	x	x	x	x	x

PE jointing methods; see CLM 2.350

T-piece, angled 45°

Dimension Ø 125 - 315 mm / SDR 11/SDR 17

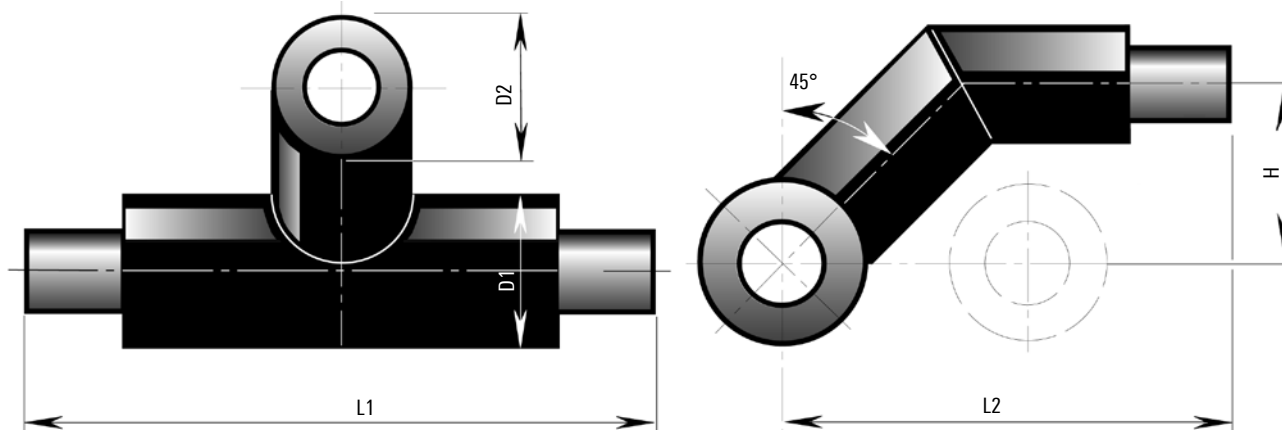

Dimensions Ø 125 - 315 mm / SDR 11/ SDR 17

Type	D1 mm	L1 m	D2 mm	L2 m	H mm
125/225	225	1.0	225	1.0	300
140/225	225	1.0	225	1.0	300
160/250	250	1.0	250	1.0	320
180/280	280	1.0	280	1.0	350
200/315	315	1.0	315	1.0	390
225/315	315	1.0	315	1.0	390
250/355	355	1.0	355	1.0	425
280/400	400	1.0	400	1.0	470
315/450	450	1.0	450	1.0	520

Other dimensions can be supplied on request.

Insulation material

PUR foam containers (Ø 125-315 mm)

Insulation material for shrink joints and shell systems

Safety regulations

Protective goggles and gloves must be worn during the foaming process.

Synthetic gloves



Protective goggles



PUR foam canister (Ø 125 - 315 mm)

CFC-free PUR foam in a canister

The required quantity of polyurethane foam is measured out with the help of foam tables and is mixed in a plastic container using a stirring device.



PE jointing methods

Fusion welded

Sleeves

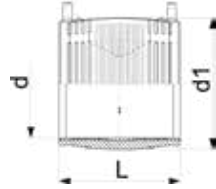

Cold water, 16 bar

Material: PE 100 / SDR 11

PE pipe mm	Sleeve mm	d1 mm	L mm
125 x 11.4	125	154	158
140 x 12.7	140	172	168
160 x 14.6	160	196	180
180 x 16.4	180	219	194
200 x 18.2	200	244	208
225 x 20.5	225	273	224
250 x 22.7	250	304	244
280 x 25.4	280	340	252
315 x 28.6	315	382	268

Reduction sleeves

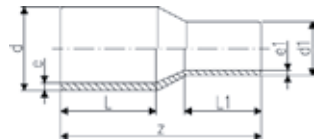

Cold water, 16 bar

Material: PE 100 / SDR 11

PE pipe mm	Sleeve mm	d mm	d1 mm	L mm	L1 mm	z mm
125 x 11.4/110 x 10.0	125/110	125	110	92	86	212
140 x 12.7/125 x 11.4	140/125	140	125	110	90	235
160 x 14.6/140 x 12.7	160/140	160	140	120	110	260
180 x 16.4/160 x 14.6	180/160	180	160	107	102	255
200 x 18.2/180 x 16.4	200/180	200	180	117	107	265
225 x 20.5/200 x 18.2	225/200	225	200	122	117	280
250 x 22.7/225 x 20.5	250/225	250	225	130	120	332
280 x 25.4/250 x 22.7	280/250	280	250	140	130	340
315 x 28.6/280 x 25.4	315/280	315	280	150	139	365

Angle piece, 90° equal

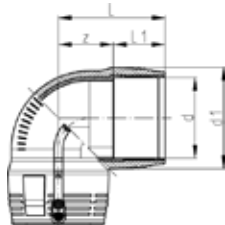

Cold water, 16 bar

Material: PE 100 / SDR 11

PE pipe mm	Sleeve mm	d1 mm	L mm	L1 mm	z mm
125 x 11.4	125	151	142	74	68
140 x 12.7*	140	only possible with spigot fittings			
160 x 14.6	160	196	178	92	86
180 x 16.4	180	219	195	95	100
200 x 18.2	200	245	265	104	161
225 x 20.5	225	274	305	112	193
250 x 22.7	250	305	335	123	212
280 x 25.4*	280	only possible with spigot fittings			
315 x 28.6*	315	dto.			

T-pieces equal

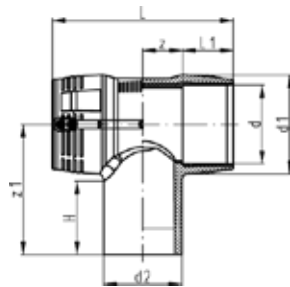

Cold water, 16 bar

Material: PE 100 / SDR 11

PE pipe mm	T-piece mm	d1 mm	L mm	L1 mm	z mm	z1 mm	H mm
125 x 11.4	125	161	276	78	60	207	113
140 x 12.7*	140	only possible with spigot fittings					
160 x 14.6	160	196	325	92	71	206	103
180 x 16.4	180	225	344	90	82	250	110
200 x 18.2	200	245	560	104	176	250	117
225 x 20.5	225	274	610	112	193	270	122
250 x 22.7	250	305	667	123	211	288	127
280 x 25.4*	280	only possible with spigot fittings					
315 x 28.6*	315	dto.					

*on request available, just as further reductions and fittings for pipe class SDR 17

(Source: Georg Fischer AG)

PE jointing methods

Alternative connections

Butt-fusion

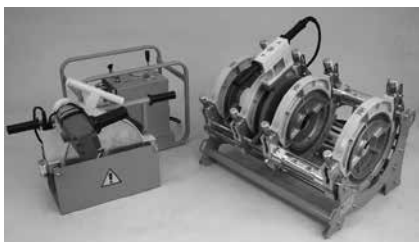

(Source: PF-Schweisstechnologie GmbH)

Mechanical pipe couplings



To join:
plastic to plastic, or
plastic to metal pipes
Ø 40 - 250 mm

(Source: Straub Werke AG)

All jointing methods listed on this sheet are available on request.

End closure

Shrink-type closure, end caps (LD-PE)

Shrink-on closure

COOLMANT shrink-on closures protect the PUR insulation on the front of the COOLMANT pipes against splashing water in buildings and shafts. **Important:** in contact with water (flooding), the shrink-on closure is not necessarily watertight! The shrink-on closure also stops gas escaping from the PUR insulation.

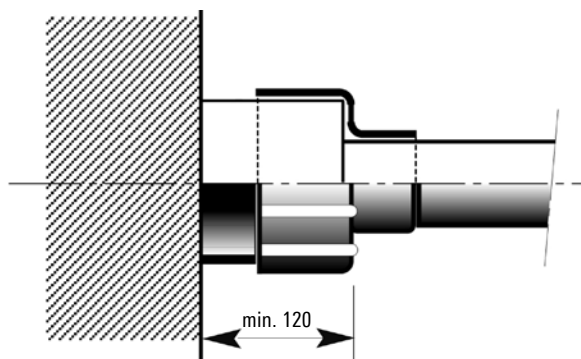

Important fitting note

COOLMANT shrink-on closures must be pushed onto the end of the COOLMANT pipes before welding the inner pipes and must be protected against the action of heat during welding.

Material:

Heat-shrunk, cross-linked polyolefin.
Coated with sealing adhesive

Wall sealing ring

for wall openings

Wall sealing ring

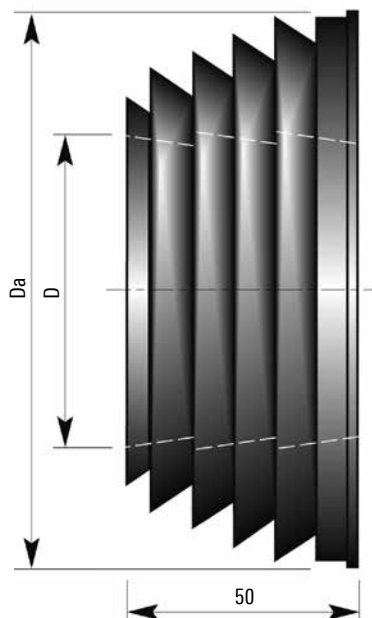

COOLMANT

Type CLM	Da
125/225	265
140/225	265
160/250	290
180/280	355
200/315	355
225/315	355
250/335	395
280/400	440
315/450	490

Pipe warning tape

- To be laid in the ground
- Standard roll length: 250 m
- Installation depth: see sheet CLM 2.505

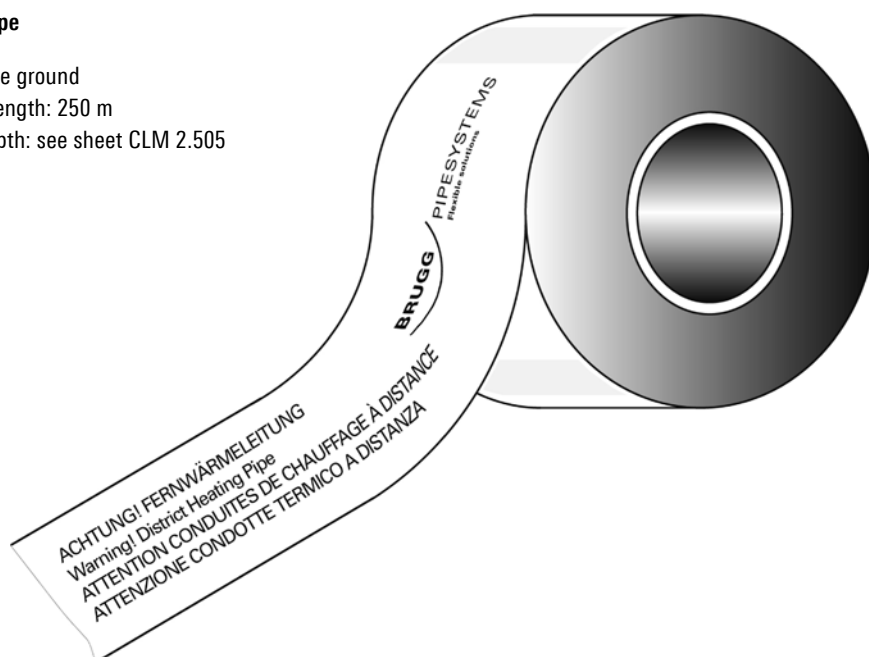

Building entry

Wall opening

Wall leadthrough

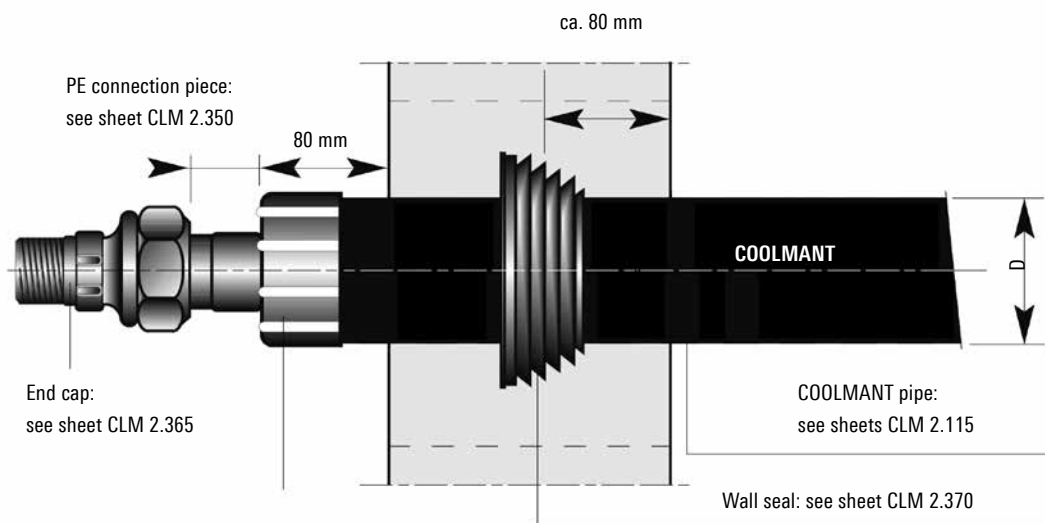

Wall opening

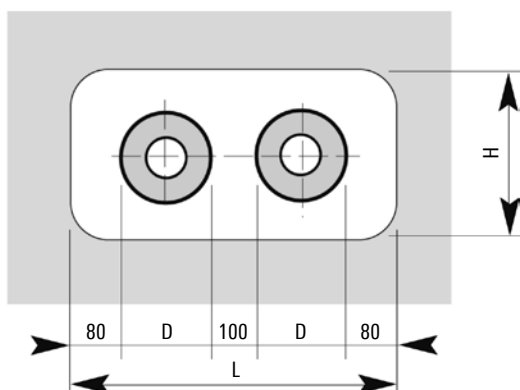

Figures in mm

Outer casing Ø D mm	L min mm	H min mm
225	810	400
250	860	400
280	920	450
315	990	450
355	1070	500
400	1160	550
450	1260	600

Building entry

Core bores/cement pipe liners

Wall leadthrough

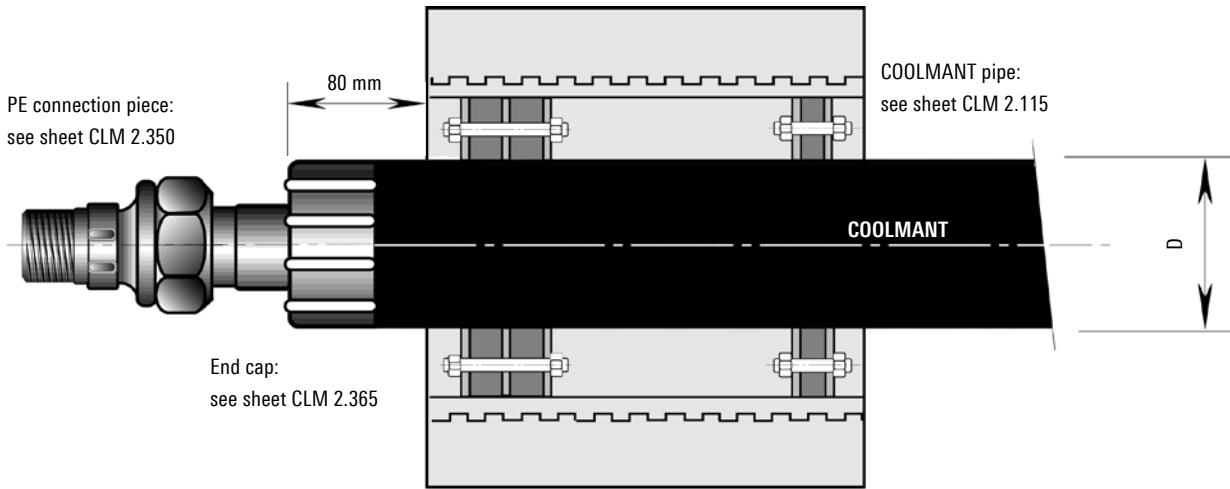

Core bores

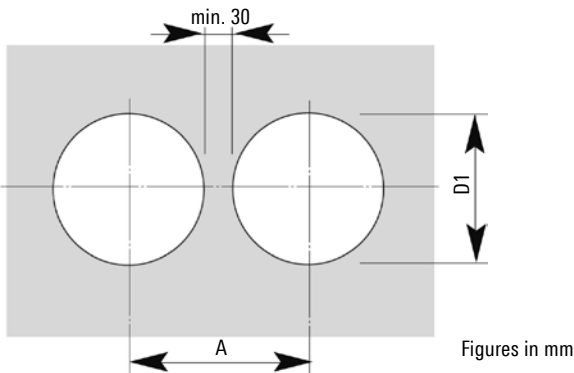

Outer casing Ø D mm	D1 mm	A mm
225	300	330
250	350	380
280	350	380
315	400	430
355	450	480
400	500	530
450	600	630

Core bores

Perfect bores are required for installation. As hairline cracks may be present in the concrete or result from drilling, it is advisable to seal the entire length of the borehole wall with suitable sealant (such as AQUAGARD).

Tightness can only be guaranteed if this recommendation is followed.

Key

- 1 COOLMANT
- 2 Sealing set, single-seal, width 1 x 40 mm, Shore hardness D35
- 3 Sealing set, double-seal*, width 2 x 40 mm, Shore hardness D35
- 4 Liner pipe: made of fiber cement or coated core bore

* Suitable for pressure from water up to 0.5 bar

Pipe routing

COOLFLEX – COOLMANT connection

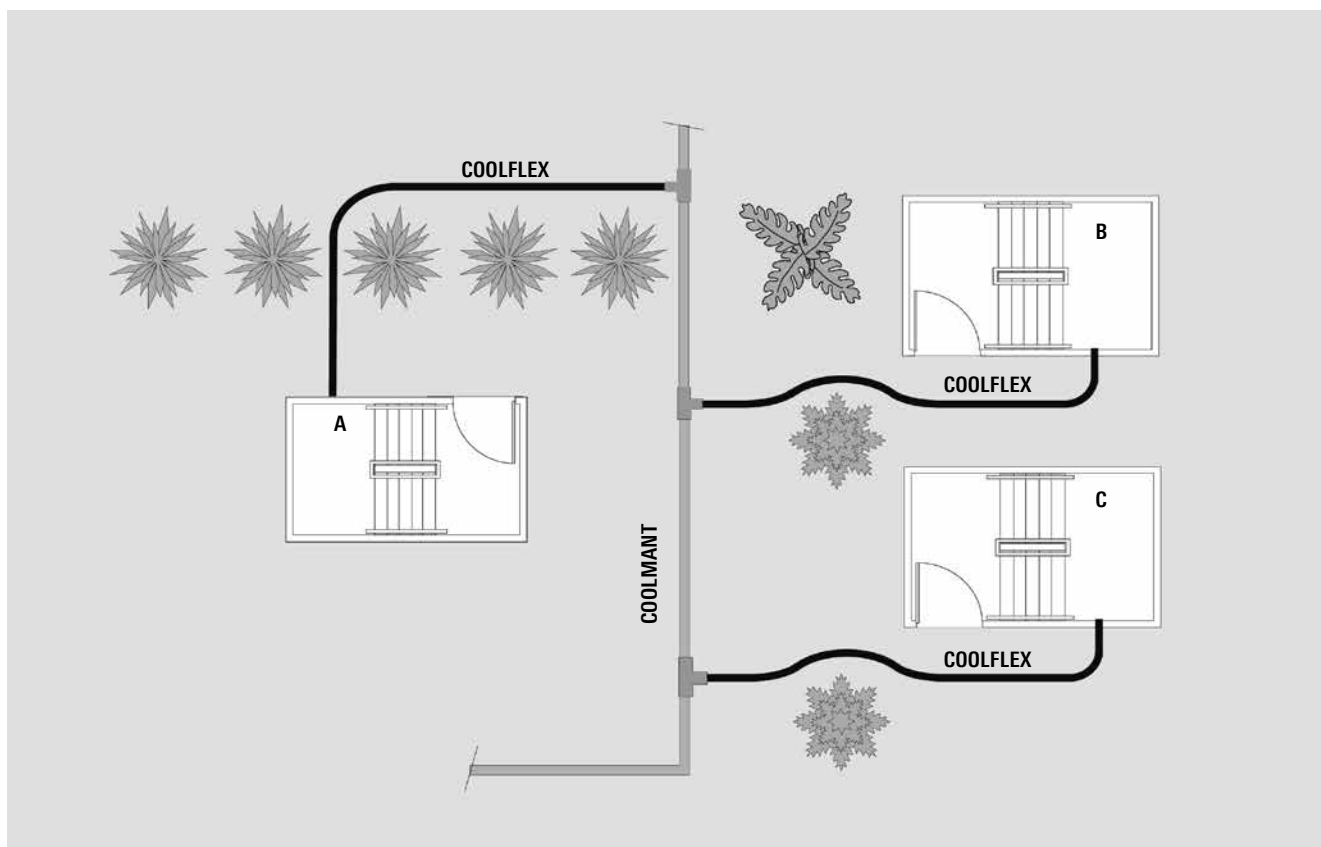

Loop-in method

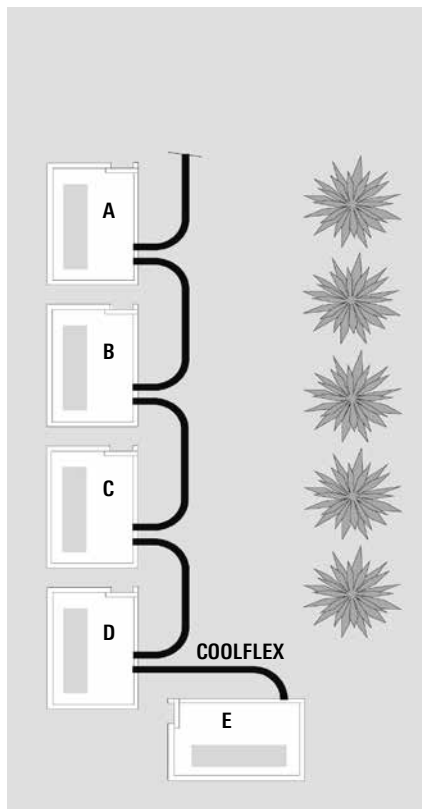

COOLFLEX – COOLFLEX connection

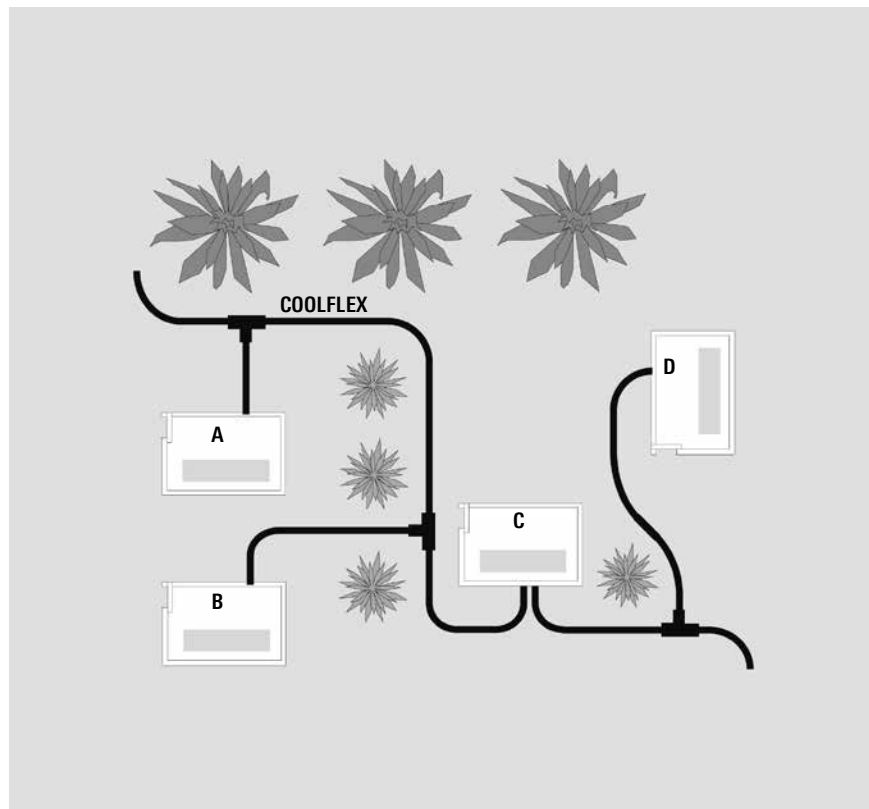

Trench dimensions

Trench profile, 2 COOLMANT pipes (\varnothing 125 - \varnothing 315)

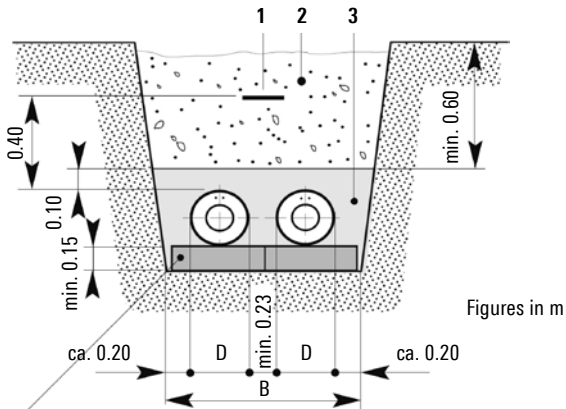

- 1 Pipe warning tape; see sheet CLM 2.370
- 2 Excavated material
- 3 Sand, washed, max. grain size 8 mm

Casing pipe \varnothing D mm	Width B cm	Depth T cm
225	105	as per trench profile
250	110	as per trench profile
280	120	as per trench profile
315	130	as per trench profile
355	135	as per trench profile
400	145	as per trench profile
450	155	as per trench profile

Installation depth:
 max. installation depth: 2.6 m
 Our approval is required for installation at greater depths.

SLW 30 \triangleq 300 kN total load as per DIN 1072; if subject to higher traffic loads (e.g. SLW 60), a load-distributing superstructure as per RSt075 is required.

With no traffic load, the minimum trench depth T can be reduced by 20 cm.

Surface installation

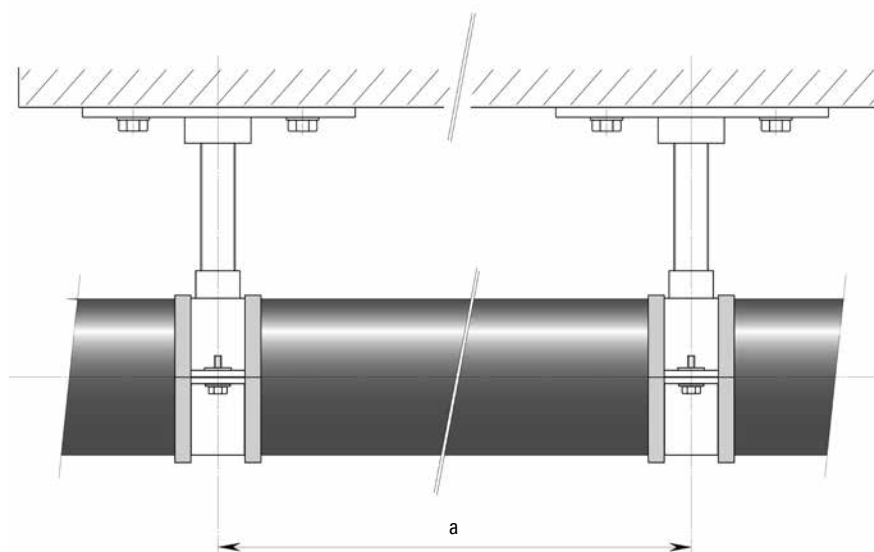

Special measures are required for surface installation of COOLMANT district cooling pipes:

- Provide supports for changes of direction
- Secure with clamps and pressure distribution plates at specified intervals, in the 90° bend
- Clamps
- Fix ends with fixed points
- Assistance with design engineering and planning from BRUGG

Type	Weight including water kg/m	Minimum Bending radius m	distance between clamps a m
125/225	15.9	–	2.0
140/225	18.8	–	2.2
160/250	24.2	–	2.4
180/280	30.6	–	2.6
200/315	38.0	–	2.8
225/315	45.7	–	3.1
250/355	56.8	–	3.3
280/400	71.4	–	3.6
315/450	90.3	–	3.9