



## Leak Monitoring Systems

for double-walled piping

Technical details

**BRUGG**  
Pipes

Leak monitoring systems

**Contents**

<b>LDS 8.0</b>	<b>Contents</b>	<b>LDS 8.26</b>	<b>Fittings for leak monitoring, general</b>
<b>LDS 8.1</b>	<b>Leak monitoring for double-walled piping</b>	LDS 8.260	Insulator, flange adapter to hose, test valves
LDS 8.100	System description	LDS 8.261	Measuring branch, manual flanging tool
LDS 8.105	Overview of leak detectors	<b>LDS 8.25</b>	<b>Fittings for vacuum leak monitoring</b>
LDS 8.120	Maximum monitoring length – double-walled piping with vacuum leak monitoring	LDS 8.251	Solenoid valve, additional measuring unit ZD 410, detonation guard, distributor block
LDS 8.130	Maximum monitoring length – double-walled piping with positive pressure leak monitoring	<b>LDS 8.34</b>	<b>Fittings for positive pressure leak monitoring</b>
<b>LDS 8.20</b>	<b>Leak monitoring with vacuum leak detector type VLR 410 PMMV Si</b>	LDS 8.342	Fittings for positive pressure leak detector type DLR-G ... PM
LDS 8.200	System description	LDS 8.343	Fittings for positive pressure leak detector type DLR-P 2.0
LDS 8.210	Technical data	<b>Leak monitoring: Checking the plant</b>	
LDS 8.213	Construction	LDS 8.270	Procedure
LDS 8.214	Laying in one line up to max. 25 bar	LDS 8.272	Type VLR 410 PMMV Si and VLX 330/A-Ex – General information
LDS 8.216	Laying in one line up to max. 25 bar with additional measuring unit ZD 410	LDS 8.273	Type <b>VLR 410 PMMV Si</b> and VLX 330/A-Ex – Checking the plant
LDS 8.217	Laying in two or multiple lines up to max. 25 bar	LDS 8.274	Type <b>VLR 410 PMMV Si</b> and VLX 330/A-Ex – Test report
LDS 8.218	Laying in multiple lines with distributor block up to max. 25 bar	LDS 8.362	Type DLR-G ... PM and DLR-P 2.0 – General information
<b>LDS 8.23</b>	<b>Leak monitoring with vacuum leak detector type VLX 330/A-Ex</b>	LDS 8.363	Type DLR-G ... PM and DLR-P 2.0 – Checking the plant
LDS 8.230	System description, technical data	LDS 8.364	Type DLR-G ... PM and DLR-P 2.0 – Test report
LDS 8.232	Construction	LDS 8.380	Locating the leak inner and outer pipe; procedure
LDS 8.233	Laying in one line up to max. 10 bar		
LDS 8.237	Laying in multiple lines with distributor block up to max. 10 bar		
<b>LDS 8.30</b>	<b>Leak monitoring with positive pressure leak detector type DLR-G ... PM</b>		
LDS 8.300	System description		
LDS 8.301	Switching pressures		
LDS 8.302	Overview, technical data, construction		
LDS 8.304	One-line system – horizontal and vertical laying		
LDS 8.305	Two and multiple line systems – horizontal and vertical laying		
<b>LDS 8.32</b>	<b>Leak monitoring with positive pressure leak detector type DLR-P 2.0</b>		
LDS 8.320	System description		
LDS 8.322	Overview, technical data, construction		
LDS 8.324	Horizontal laying with gradient to the tank		

Leak monitoring systems

# Leak monitoring for double-walled piping

## System description

### The leak monitoring

Double-walled piping is permanently monitored using pneumatic leak detecting devices. These regulate the monitoring pressure in the surveillance space and register any changes of pressure which may occur. The surveillance space prevents uncontrolled spillages of the transport medium when leaks occur. The surveillance space must be so constructed that the functioning and operative security of the leak monitoring system (the leak detector) is assured at all times. The size of the surveillance space for each leak detector is limited to 10 m<sup>3</sup> acc. to DIN EN 13160.

If the pipe is damaged the alarm is given by acoustic and optical signals.

### Definition of leak detection equipment/leak detector

“Leak detection equipment/leak detector” according to the currently valid regulations refers to a device which automatically and under all operating conditions gives warning of leaks in the walls of double-walled piping in which water hazardous (flammable and non-flammable) fluids are transported. The term “leak detection equipment/leak detector” includes all the equipment necessary for the detection of leaks.

The main components are:

- the leak detector/leak monitoring equipment
- the connection between the surveillance space and leak detector)
- double-walled piping:  
FLEXWELL® Safety Pipe  
BRUGG-STAMANT® Safety Pipe  
SECON®-X Petrol station pipe
- the surveillance space
- a leak detection medium

The use of this system complies with the most stringent European safety standards (Class 1). Systems of this class give warning of a leak above or below the fluid level in a double-walled protective system. They are constructed on the principles of absolute safety and ensure that spillages of products into the environment cannot occur.

### Leak detector

We distinguish two types of differential pressure leak detection equipment: Leak surveillance to detect leaks in double-walled piping on the vacuum principle and on the positive pressure principle.

### Approval/suitability

All leak detection equipment/leak detectors in use must comply with the basic criteria laid down for construction and testing standards. All such preconditions which could have a bearing on the functional and operative safety of the system must therefore be observed.

It therefore goes without saying that the conditions for operative use have been tested by the competent authorities and clearly defined and set down in the documents of approval issued by them.

Double-walled piping with leak monitoring is an approved leak detection equipment/leak detector system.

### The advantages of the system

Using double-walled FLEXWELL® Safety Pipe with leak monitoring offers, besides a high degree of operative safety, substantial economic advantages:

- the entire system can be easily and simply monitored at any time without interrupting operations
- requirements such as e.g. pressure/volume measurements, pressure tests or route surveys can be dispensed with
- when a leak occurs, operations can normally be continued without interruption; repairs can be planned.

double-walled piping with vacuum leak detector

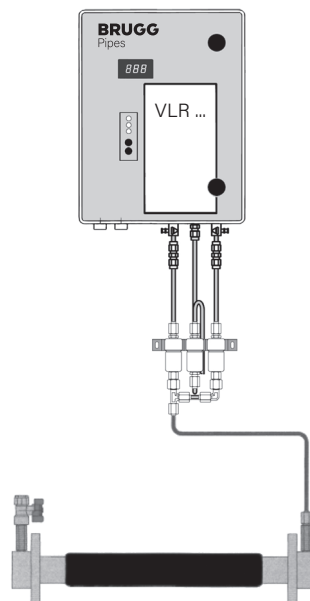

double-walled piping with positive pressure leak detector

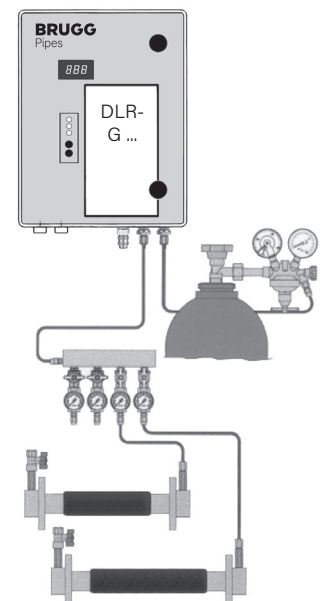

Leak monitoring systems

# Leak monitoring for double-walled piping

## Overview of leak detectors

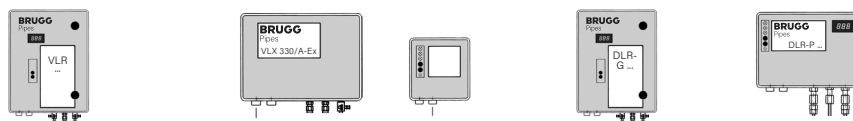

Type of leak detector	VLR 410 PMMV Si	VLX 330/A-Ex	Detector unit	DLR-G ... PM	DLR-P ...
<b>Type of pipe</b>					
FLEXWELL® Safety Pipe	•	•	•	•	•
BRUGG-STAMANT® Safety Pipe	•	•	•	•	–
SECON®-X Petrol Station Pipe	•	•	•	–	•
<b>Area for installation</b>					
Dry and frost-free area	•	•	•	•	•
Outside buildings	•	•	–	•	–
	•	•	•	•	•
	•	–	–	–	–
<b>Flashpoint of transport medium</b>					
< 55 °C	–	•	•	•	•
> 55 °C	•	•	•	•	•
Max. pipe length see worksheet	LDS 8.120	LDS 8.120		LDS 8.130	LDS 8.130
Max. operating pressure	25 bar	10 bar		22 bar	1 bar
Potential-free relay	•	•	•	•	•
Dimensions of housing (H x B x T) in mm	280 x 230 x 130	300 x 200 x 160		280 x 230 x 130	210 x 260 x 110
Dimensions detector unit		200 x 120 x 90			
Additional criteria for selection	Compact, uncomplicated leak detector for consumer heating oil plants	Leak detector for flammable media with minimum maintenance		Electronic leak detector for all pressure stages	Reliable leak detector for petrol stations low operating pressure

\* Also available as a version with an additional sensor for drip trays.

### Please note

- monitorable pipe lengths acc. to Worksheets LDS 8.120 and LDS 8.130
- observe the effective area as well as the Ex zones
- Queries refer to all the piping to be monitored and all media transported
- the permissible operating and surveillance space pressures of the various pipe systems must be considered

### Monitorable pressures

Type	vacuum leak monitoring		positive pressure leak monitoring	
	max. pressure inner pipe bar	max. pressure surveillance space bar	max pressure inner pipe bar	max. pressure surveillance space bar
FLEXWELL® Safety Pipe (all sizes)	25	–0.7	22	25
SECON®-X 25	3.5	–0.7	2.0	3.5
SECON®-X 40	3.5	–0.7	2.0	3.5
SECON®-X 50	3.5	–0.7	2.0	3.5
SECON®-X 100	3.5	–0.7	1.0	2.5
BRUGG-STAMANT® Safety Pipe	acc. to project on request / References up to 400 °C and 250 bar			
Special piping	acc. to project on request			

Leak monitoring systems

# Maximum monitoring length

## Double-walled piping with vacuum leak monitoring

**Basis**

ZG-LAGR principles of approval for leak monitoring equipment for double-walled piping

**Determining the maximum monitorable pipe length**

Half the alarm-triggering pressure loss "on" in [mbar] of the leak detector used, with certificate of suitability for approval by the building authorities from the DIBt (Deutschen Institut for Bautechnik), divided by the pressure loss per metre in the surveillance space gives the maximal monitorable pipe length.

$$L_{max.} = \frac{\text{alarm-triggering pressure loss "on" [mbar]}}{2 \cdot \text{pressure loss [mbar/m]}}$$

Monitorable pipe length for **SECON®-X** L max. = 500 m.

**Exception:** SEC 25 with VLX 330 A/Ex = 335 m resp. VLR 410 / E = 415 m

Sum of all ind. lengths L max. ≤ 2000 m

**Example**

Type of laying	single line
Alarm-triggering pressure loss "on"	410 mbar
Half alarm-triggering pressure loss	205 mbar
Type of pipe	FSR 60/83
max. monitorable pipe length L max.	~ 460 m

**Diagram for horizontal laying of double-walled piping**  
**FLEXWELL® Safety Pipe (FSR)**

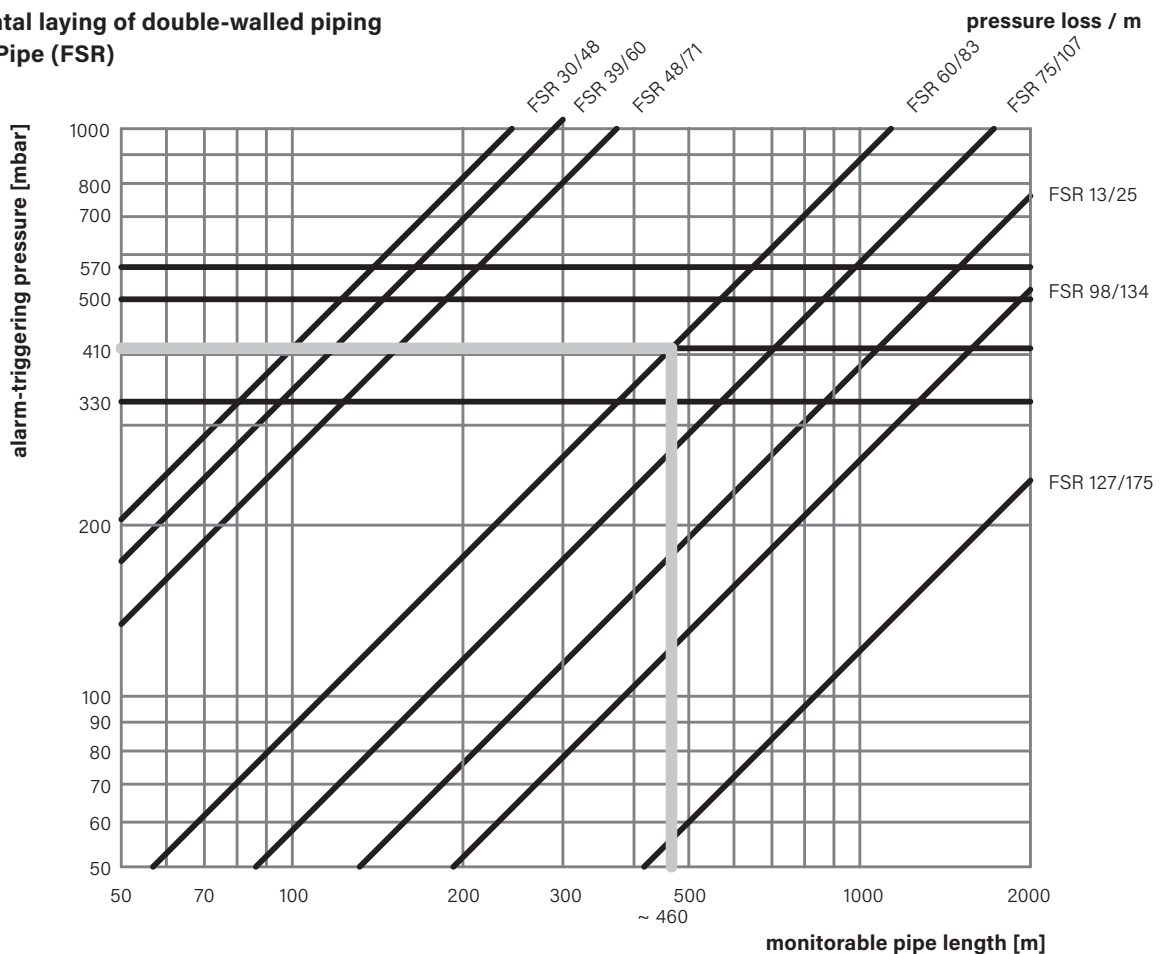

Leak monitoring systems

# Maximum monitoring length

## Double-walled piping with positive pressure leak monitoring

**Basis**

ZG-LAGR principles of approval for leak monitoring equipment for double-walled piping

**Determining the maximum monitorable pipe length**

Half the alarm-triggering pressure loss "on" in [mbar] of the leak detector used, with certificate of suitability for approval by the building authorities from the DIBt (Deutschen Institut for Bautechnik), divided by the pressure loss per metre in the surveillance space gives the maximal monitorable pipe length.

$$L_{max.} = \frac{\text{differential pressure in surveillance space [mbar]}}{2 \cdot \text{pressure loss [mbar/m]}}$$

Monitorable pipe length for **SECON®-X** L max. = 500 m.

**Exception:** SEC 25 with DLR-P 2.0 = 405 m

Sum of all ind. lengths L max. ≤ 2000 m

**Example**

Type of laying	single line
Transport pressure in operating pipe	5 bar
Monitoring pressure in surveillance space	7 bar
Alarm-triggering pressure rise „on“	6 bar
Differential pressure in the surveillance space	1 bar
Alarm-triggering pressure rise „on“ 6 bar gives	1000 mbar differential pressure/ 400 mbar with DLR-P 2.0
Half alarm-triggering pressure rise	500 mbar
Type of pipe	FSR 60/83
max. monitorable pipe length L max.	1100 m/ 450 m with DLR-P 2.0

**Diagram for horizontal laying of double-walled piping FLEXWELL® Safety Pipe (FSR)**

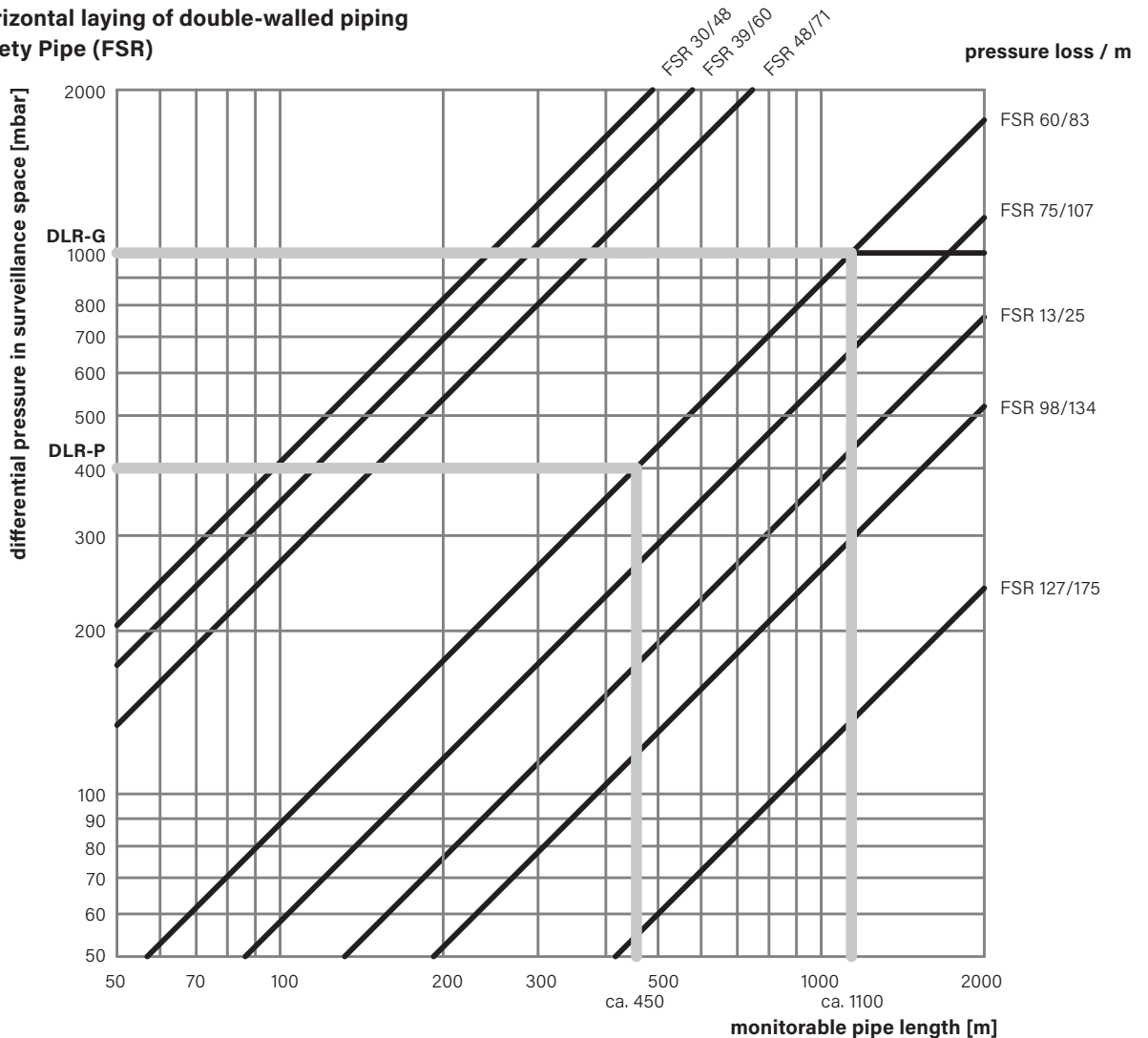

Leak monitoring systems

# Vacuum leak detector type VLR 410 PMMV Si

## System description

### Leak monitoring on the vacuum principle

The vacuum leak detector type VLR is suitable and approved for the monitoring of double-walled piping used for transporting water-hazardous flammable substances with a flashpoint > 55 °C (e.g. heating oil, diesel fuel, water-glycol mixture, AD Blue, ...).

### Versions

VLR 410 PMMV Si: max. operating pressure in the inner pipe 25 bar (a leakage probe or a solenoid valve or both can be connected in addition).

### Alarm-triggering values

VLR 410 PMMV Si: on > 410 mbar

### Functioning principle

The vacuum pump installed in the leak detector creates a partial vacuum in the surveillance space. This partial vacuum is measured by a pressure sensor. Through monitoring the vacuum, leaks are therefore automatically detected.

In the event of a drop in the partial vacuum below the lower value of the monitoring partial vacuum (pressure rise) due to a leak, an optical and acoustic alarm is triggered. Minimal, unavoidable permeability (not leaks) are regulated automatically by the leak detector without triggering the alarm if they lie between the upper and lower values of the monitoring partial vacuum. Subsequent evacuation is carried out by the vacuum pump in the leak detector.

In every case in which the alarm is triggered by the VLR410/E the vacuum pump is automatically switched off. It can only be switched on again by throwing the toggle switch "Operation".

### Technical basis

The scope of application of the leak detection device must be limited to fixed maximum pipe lengths due to the laws of physics. These depend on upper and lower points of reference and on the type of laying of the double-walled safety piping. The types of laying are illustrated in the Worksheets LDS 8.214 ff.

### Tips for installation

The leak detector may not be installed in explosion-proof areas. The installation of the leak detector can be inside closed, dry rooms or outside of buildings.

### Installation/commencement of operations/operation/function testing

Detailed descriptions can be seen from the approval documentation of the VLR leak detector. The conditions set out in the approval for double-walled piping and the VLR leak detector must be complied with.

Example leak monitoring diagram Vacuum

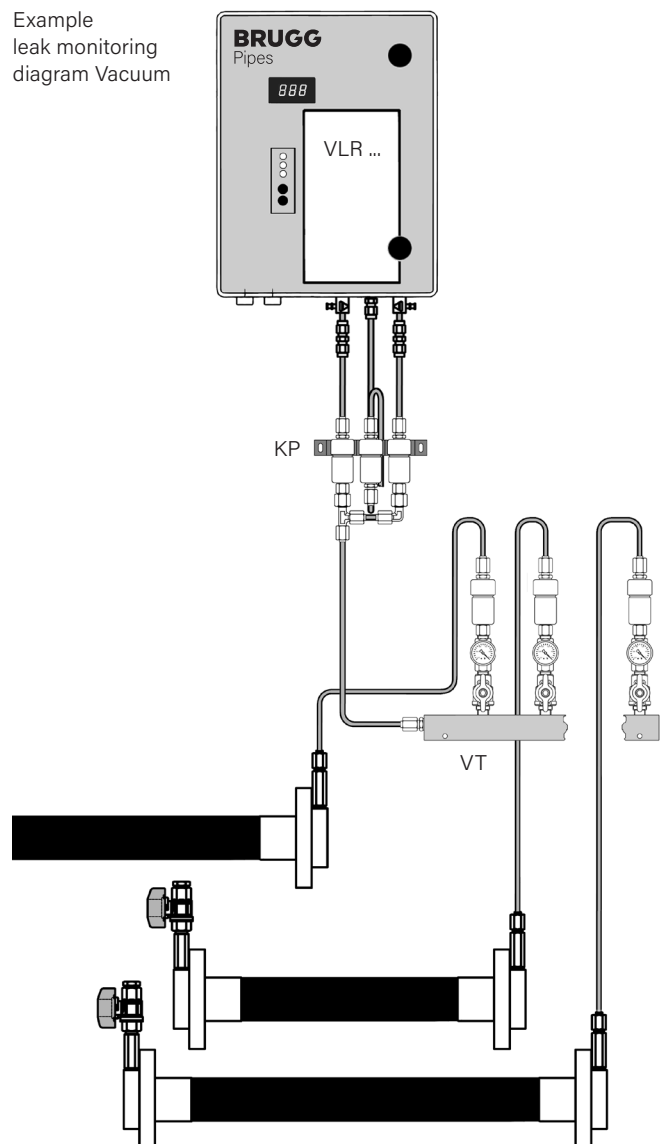

Leak monitoring systems

**Vacuum leak detector type VLR 410 PMMV Si**

Technical data

**Overview leak detector type VLR 410 PMMV Si**

Applications	water-hazardous fluids with a flashpoint > 55 °C, without the occurrence of explosive vapour-air mixtures. From flashpoint < 55 °C: VLX... in Ex version	
Monitorable pipe length	L max = max. monitorable pipe length acc. to laying procedure (see Worksheet LDS 8.120, for underground and surface-laid pipes.	
Operating pressure	up to max. 25 bar VLR 410/E (with operating pressure from 5 bar a solenoid valve must be used)	
Installation area	Install inside an enclosed, dry room with no access for unauthorized personnel or outside buildings. Installation in areas where there is a danger of explosions is not permitted.	
Installation in the open/ in damp rooms	inside a suitable metal housing, depending on the requirements – optical and acoustic signal	
Housing dimensions	Height: 280 mm, width: 230 mm, depth: 130 mm	
Fittings	Insulating piece with flanged screw connection to separate the metal connection in earthed installations acc. to TRbF 521.	
Electrical data	Rated input (without external signal)	230 V~/50 Hz/50 W
	Switching contact load, connector block AS (5 and 6)	230 V~/50 Hz/200 VA
	Switching contact load, potential-free contacts, connector block 11 to 12	max. 230 V~/50 Hz/5 A min. 6 V/10 mA
	External fuse protection of the leak detector	max. 10 A
	Overvoltage category	2

Leak monitoring systems

**Vacuum leak detector type VLR 410 PMMV Si**

Construction

**Construction vacuum leak detector type VLR 410 PMMV Si**

Article No. 1057106

- BV three-way stopcock  
suction pipe
- GD three-way stopcock  
measuring lead
- FL fluid barrier
- A signal lamp „Alarm“
- A1 signal lamp Alarm 2  
(leak probe)
- B signal lamp  
„Operations“
- TA Switch-key  
acoustic signal
- KS Switch-key  
commence  
operations
- K Crosspoint
- AV Connection fitting

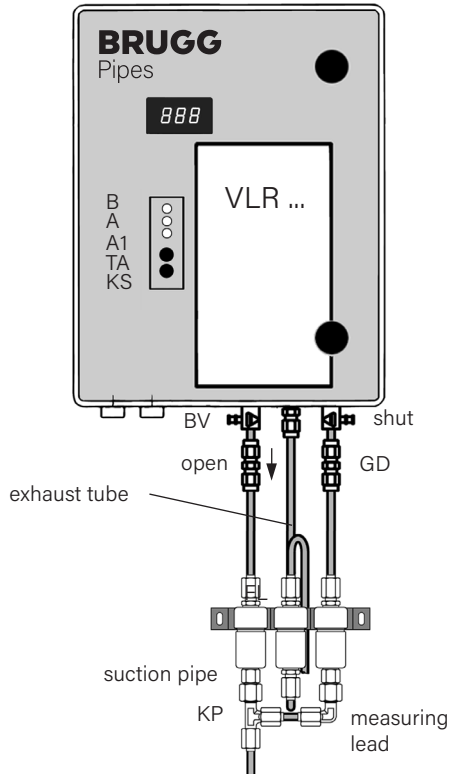

**Connected to a single-line system (Worksheet LDS 8.214 and 8.216)**

**Multiple-line system with distributor block (Worksheet LDS 8.218)**

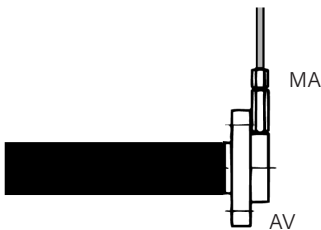

Suction pipe and measuring lead of the leak detectors are connected by means of a screwed T-piece (crosspoint KP) and connected to the connection fitting AV by a measuring branch MA.

**Connected to a multiple-line system**

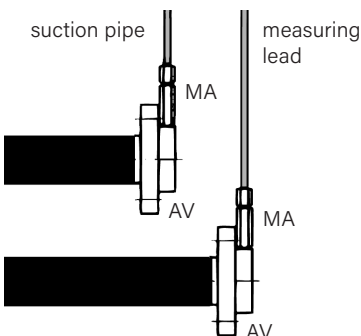

When several double-walled piping lines are connected, the individual surveillance spaces are directly connected via the distributor block or switched in-line. The suction pipe is connected at the front, the measuring lead at the end of the series. The surveillance spaces of the piping lines are connected together. All connection and connection fittings are connected to the connection fitting AV by means of a measuring branch MA.

Leak monitoring systems

**Vacuum leak detector type VLR 410 PMMV Si**

Laying in a single line up to max. 25 bar

**Connecting the leak detector to the surveillance space of the double-walled safety pipe (Worksheet LDS 8.213)**

A test valve must be installed at the far end of the pipe. The low point(s) must not exceed a depth of 3.5 m. The piping can have further high or low points as long as the sum of the high and low points does not exceed 3.5 m.

- MA Mesasuring branch
- AV connection fitting
- PV test valve
- KP cross point
- PB transport pressure in inner pipe
- MV solenoid valve
- FL fluid barrier

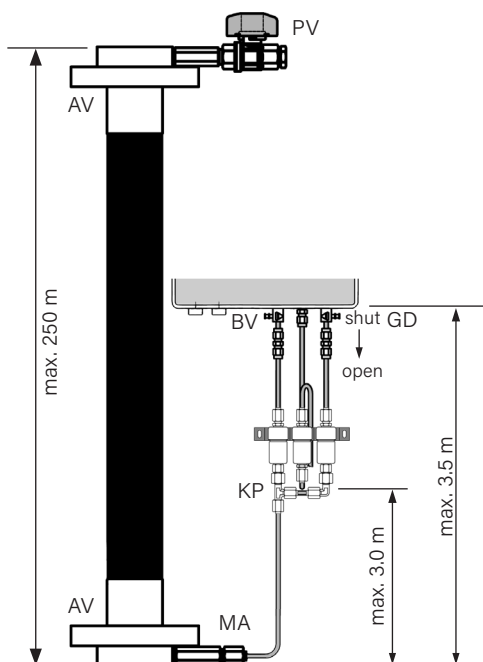
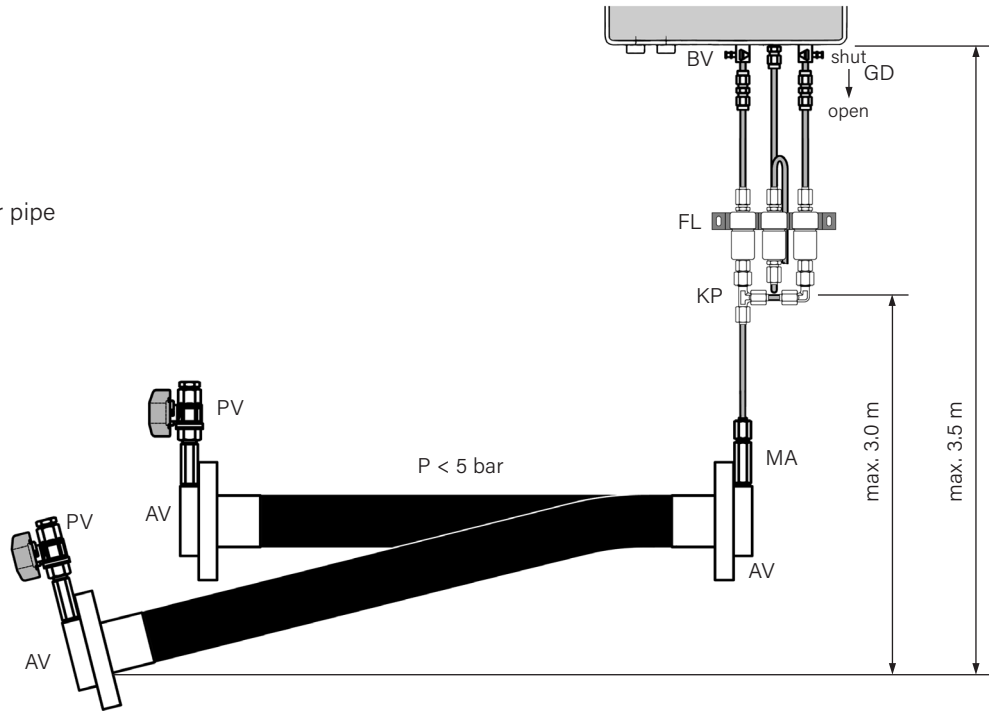

At a PB > 5 bar up to max. 25 bar a solenoid valve MV must be installed between the crosspoint KP and the measuring branch MA.

The solenoid valve protects the leak detector from non-permissible high pressures. The solenoid valve is monitored electronically so that a failure of the solenoid valve triggers the alarm.

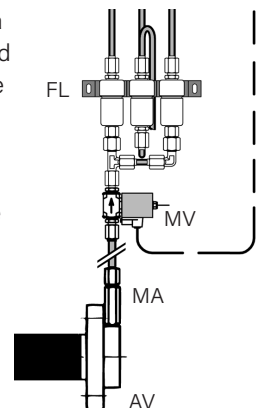

Leak monitoring systems

**Vacuum leak detector type VLR 410 PMMV Si**

Laying in one line up to max. 25 bar with additional measuring unit ZD 410

If the maximum monitorable length acc. to Worksheet LDS 8.120 is not sufficient for an individual case the additional measuring unit ZD 410 must be installed.

Max. monitorable pipe length	L max.
SECON®-X DN 25	
FSR 30/48	
FSR 39/60	
FSR 48/71	500 m
all other SEC and FSR sizes	2000 m

**Connecting the leak detector to the surveillance space of the double-walled safety pipe (Worksheet LDS 8.213)**

The leak detector is connected as shown in the illustration in Worksheet LDS 8.213. An additional measuring unit type ZD 410 is installed at the other end of the pipe using the same connection method. The additional measuring unit type ZD 410 is electrically connected to the leak detector VLR10/E.

- MA Measuring branch
- A connection fitting
- KP crosspoint
- FL fluid barrier
- PD three-way stopcock
- ZD 410 additional measuring unit
- PB transport pressure in inner pipe
- MV solenoid valve
- SL electric control lead type NYY 3 x 1,5<sup>2</sup>

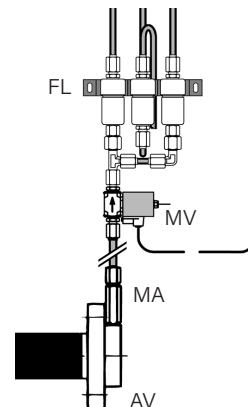
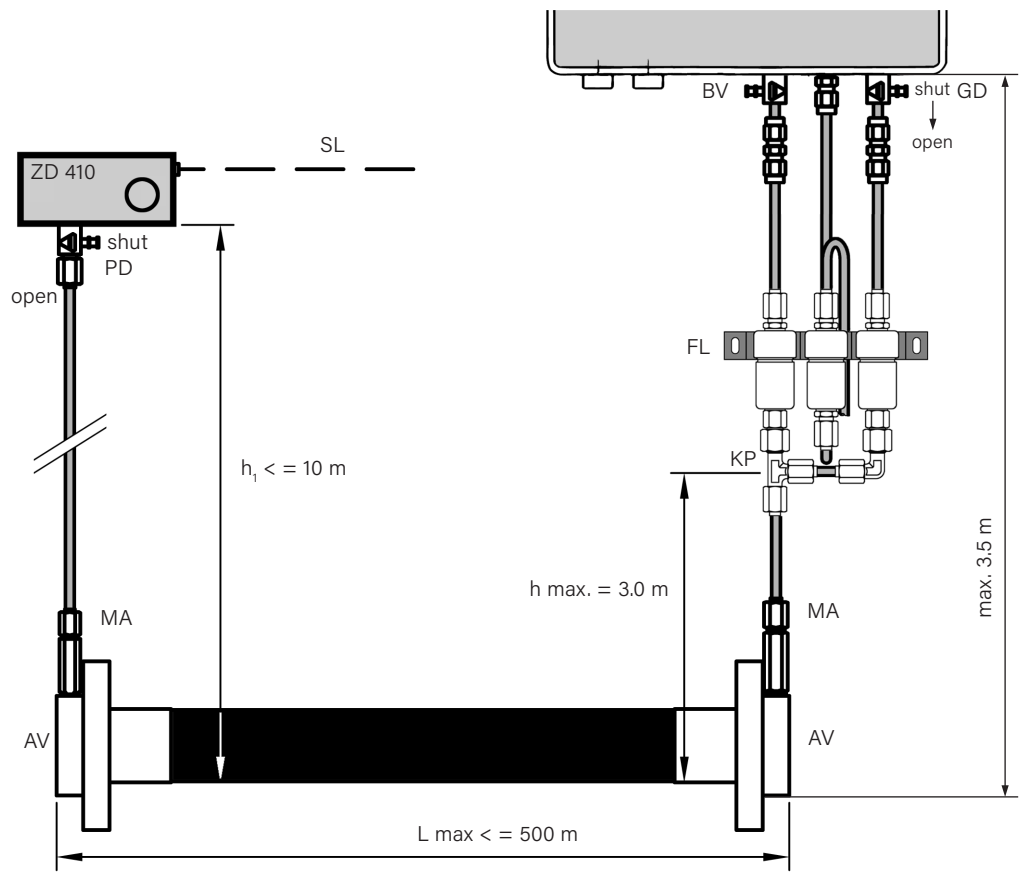

At a PB > 5 bar up to max. 25 bar a solenoid valve MV must be installed between the crosspoint KP and the measuring branch MA.

The solenoid valve protects the leak detector from non-permissible high pressures. The solenoid valve is monitored electronically so that a failure of the solenoid valve triggers the alarm.

Leak monitoring systems

### Vacuum leak detector type VLR 410 PMMV Si

Laying in two or multiple lines up to max. 25 bar

**Connecting the leak detector to the surveillance space of the double-walled safety pipe (Worksheet LDS 8.213)**

The geodetic difference in height between the lowest point of the piping and the leak detector must not exceed 3.5 m. The depth of 3.5 m is the limiting line between the "highest" and "lowest" low points.

<b>Max. monitorable pipe length =</b>	
<b>sum of all ind. lengths</b>	<b>L max.</b>
<b>all SECON®-X types</b>	
<b>FSR 30/48</b>	
<b>FSR 39/60</b>	
<b>FSR 48/71</b>	<b>500 m</b>
<b>all other FSR sizes</b>	<b>2000 m</b>

- MA measuring branch
- AV connection fitting
- MV solenoid valve
- BV ventilation valve
- GD three-way stopcock
- FL fluid barrier

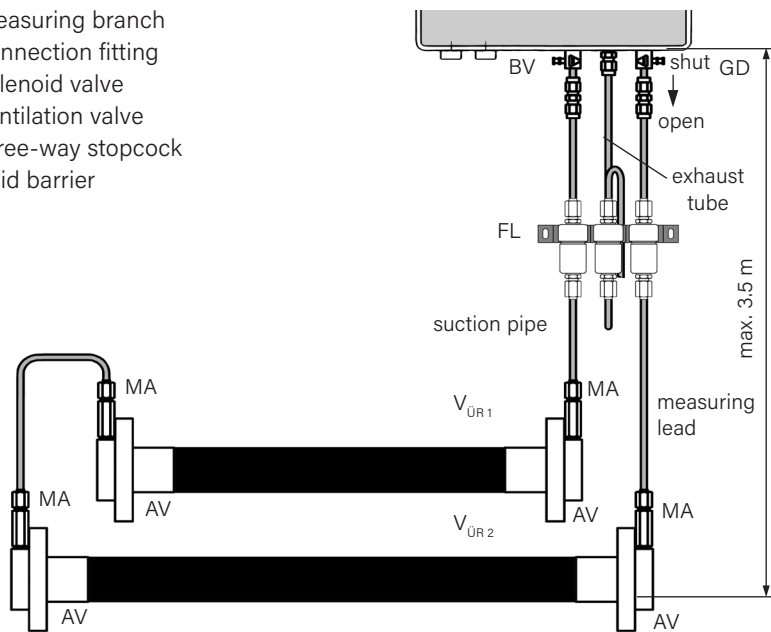

Leak monitoring systems

**Vacuum leak detector type VLR 410 PMMV Si**

Laying in multiple lines with distributor block up to max. 25 bar

**Connection of the leak detector to the distributor block (Worksheet LDS 8.213)**

The individual surveillance spaces of the double-walled piping lines are connected using the measuring branch MA to the outlets of the distributor block. When laying in multiple lines, the double-walled piping may have high and low points as described in Worksheet LDS 8.214 for laying in a single line, as long as the sum of the high and low points does not exceed 3.5 m.

- MA measuring branch
- AV connection fitting
- PV test valve
- KP crosspoint
- MV solenoid valve
- BV ventilation valve
- GD three-way stopcock
- VT distributor block
- FL fluid barrier

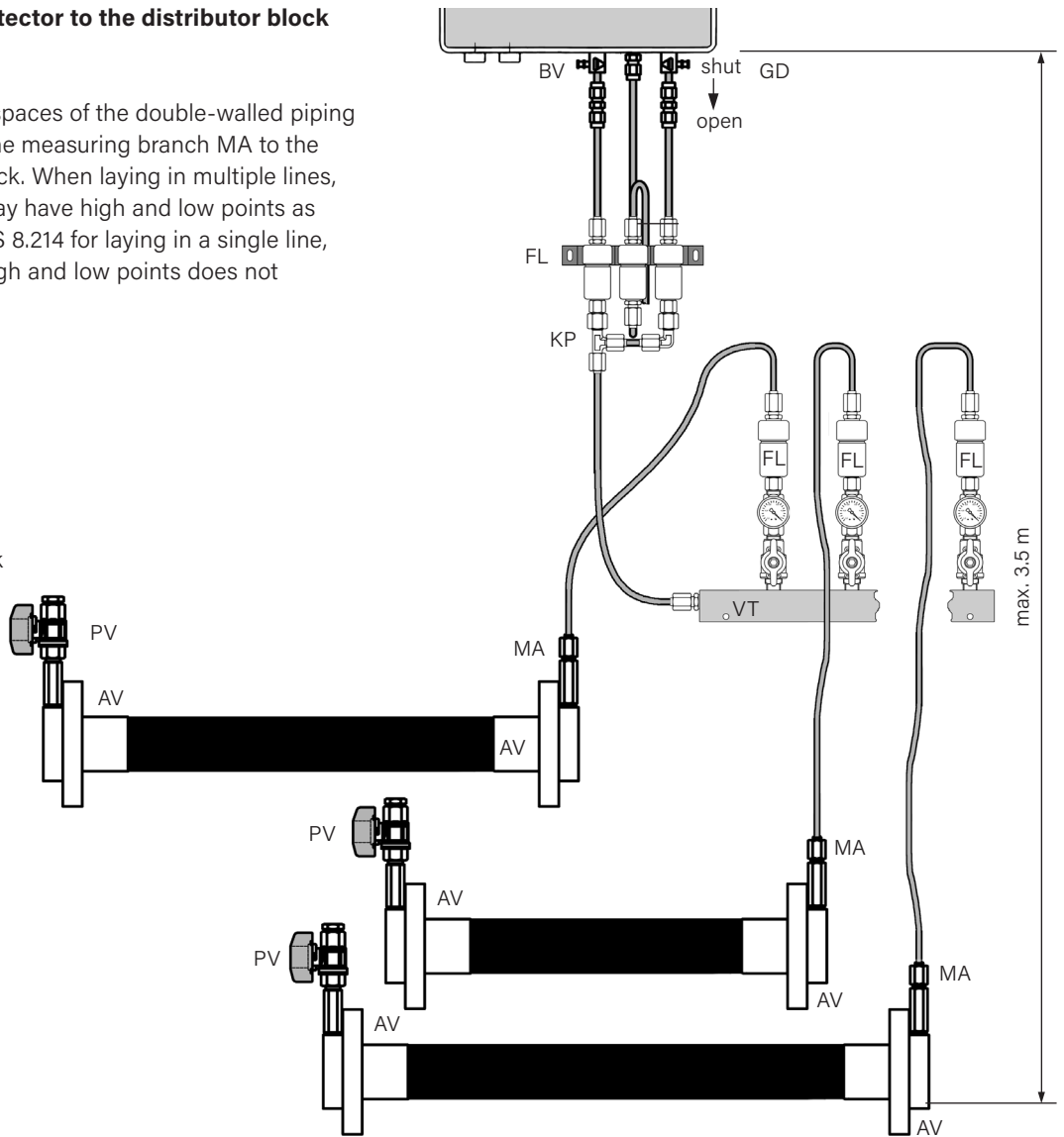

At PB > 5 bar up to max. 25 bar a solenoid valve MV must be installed between the crosspoint KP and the connection to the distributor block VT.

The solenoid valve protects the leak detector from non-permissible high pressures. The solenoid valve is monitored electronically so that a failure of the solenoid valve triggers the alarm.

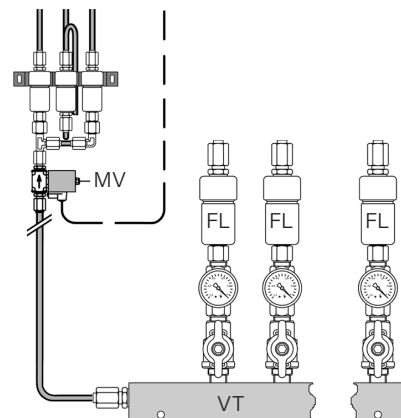

Leak monitoring systems

**Vacuum leak detector type VLX 330/A-Ex**

System description, technical data

**Type VLX 330/A-Ex, version with partial protection from explosions**

The vacuum leak detector type VLX 330/A-Ex is suitable and approved for monitoring double-walled safety piping through which the following fluids are transported:

- Flashpoint < 55 °C
- water-hazardous, flammable fluids with a possible occurrence of potentially explosive vapour-air mixtures assignable to explosion categories IIA or IIB3 and temperature category T1 to T3 (e.g., petrol, motor fuels in general, ...)

Double-walled components may be integrated into the piping. Approved for a max. operating pressure in the operational pipe

Type VLX 330/A-Ex ... **up to max. 10 bar**  
 Type VLX 330/A-MV-Ex **up to max. 25 bar**

**Installation/commencement of operations/operation/function testing**

The scope of application of the leak detection device must be limited to fixed maximum pipe lengths due to the laws of physics. These depend on upper and lower points of reference and on the type of lying of the double-walled safety piping. The types of laying are illustrated in the Worksheets LDS 8.233 ff.

The conditions set out in the approval for double-walled piping and for the leak detector must be complied with.

**Overview of leak detector VLX 330/A-Ex**

Applications	Water-hazardous fluids with a flashpoint < 55 °C, with a possible occurrence of potentially explosive vapour-air mixtures assignable to explosion categories IIA or IIB3 and temperature category T1 to T3 (e.g., petrol, motor fuels in general, ...)	
Operating pressure in inner pipe	VLX 330/A-Ex:	max. 10 bar
	VLX 330/A-MV-Ex:	max. 25 bar
Monitorable pipe length	L max = monitorable pipe length acc. to Worksheet LDS 8.120 for underground and surface-laid pipes	
Installation area	acc. to installation instructions and description of leak detector VLX 330/A-Ex	
Installation	see description of leak detectors VLX 330/Ex and VLX 330/A-Ex	
Housing	VLX 330/A-Ex comprises a control unit and the working device	
Fittings	fittings set out in the programme for the leak detector and the double-walled piping	
Electrical data	Rated input (without external signal)	230 V~/50 Hz/50 W
	Switching contact load, potential-free contacts	max. 230 V~/50 Hz/5 A
	Connector block 21 - 24	min. 6 V/10 mA
	External fuse predection of the leak detector	max. 10 A
	Overvoltage category	2

**On request, type VLX 330/Ex can be delivered in a completely explosion-protected version.**

Leak monitoring systems

# Vacuum leak detector type VLX 330/A-Ex

## Construction

### Construction vacuum leak detector type VLX 330/A-Ex

Article No. 1015790

- BV screwed flange connection
- GD three-way stopcock measuring lead/suction pipe
- DS detonation protection
- FL fluid barrier
- DG pressure compensating vessel

### Construction vacuum leak detector type VLX 330/A-MV-Ex (available on request)

In the type VLX 330/A-MV-Ex an additional solenoid valve is integrated into the leak detector.

**If the working device is used in a „Non-Ex area“, the exhaust tube must be relocated to an Ex area of Zone I.**

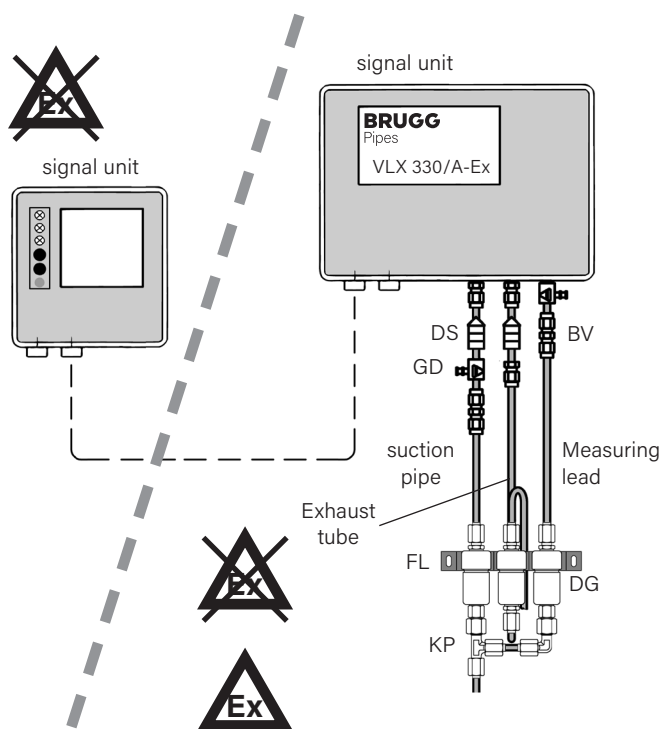

### Construction vacuum leak detector type VLX 330/Ex

Article No. 1015801  
(available on request)

- BV screwed flange connection
- GD three-way stopcock measuring lead/suction pipe
- DS detonation protection
- FL fluid barrier
- KP crosspoint
- DG pressure compensating vessel

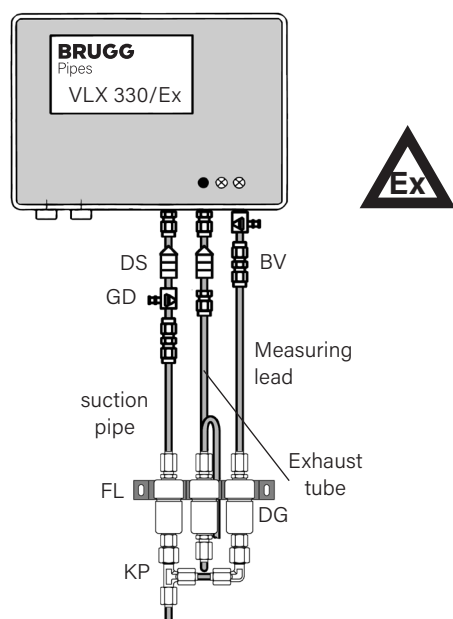

Leak monitoring systems

**Vacuum leak detector type VLX 330/A-Ex**

Laying in one line up to max. 10 bar

**Connecting the leak detector to the surveillance space of the double-walled piping (Worksheet LDS 8.232)**

A test valve must be installed at the far end of the pipe. The low point(s) must not exceed a depth of 3.5 m. The piping can have further high or low points as long as the sum of the high and low points does not exceed 3.5 m.

- MA measuring branch
- DS detonation protection (only if Ex danger)
- AV connection fitting
- PV test valve
- KP crosspoint

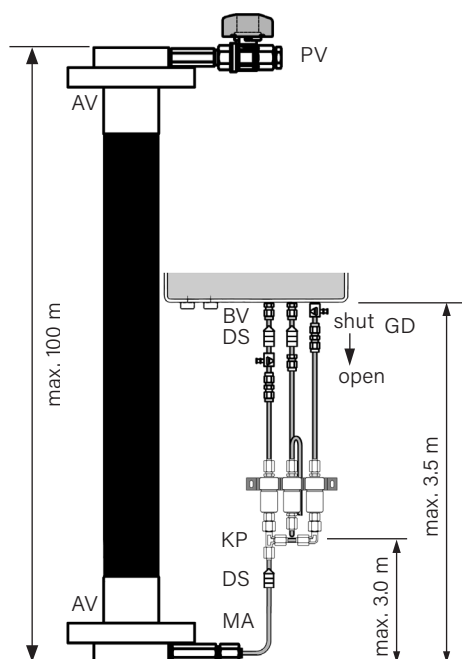
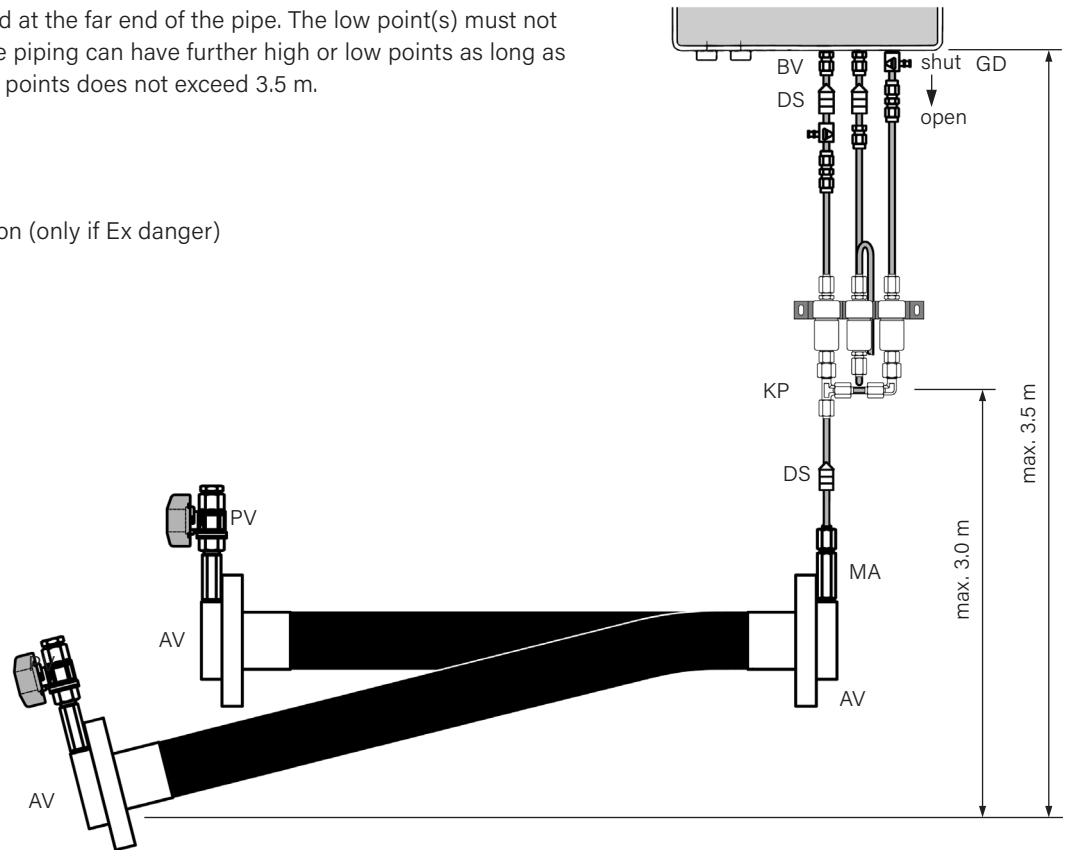

Leak monitoring systems

**Vacuum leak detector type VLX 330/A-Ex**

Laying in multiple lines with distributor block up to max. 10 bar

The individual surveillance spaces of the double-walled piping lines are connected using the measuring branch MA to the outlets of the distributor block. When laying in multiple lines, the double-walled piping may have high and low points as described in Worksheet LDS 8.233 for laying in a single line, as long as the sum of the high and low points does not exceed 3.5 m.

- MA measuring branch
- DS detonation protection (only if Ex danger)
- AV connection fitting
- PV test valve
- VT distributor block
- FL fluid barrier connected against the reverse direction

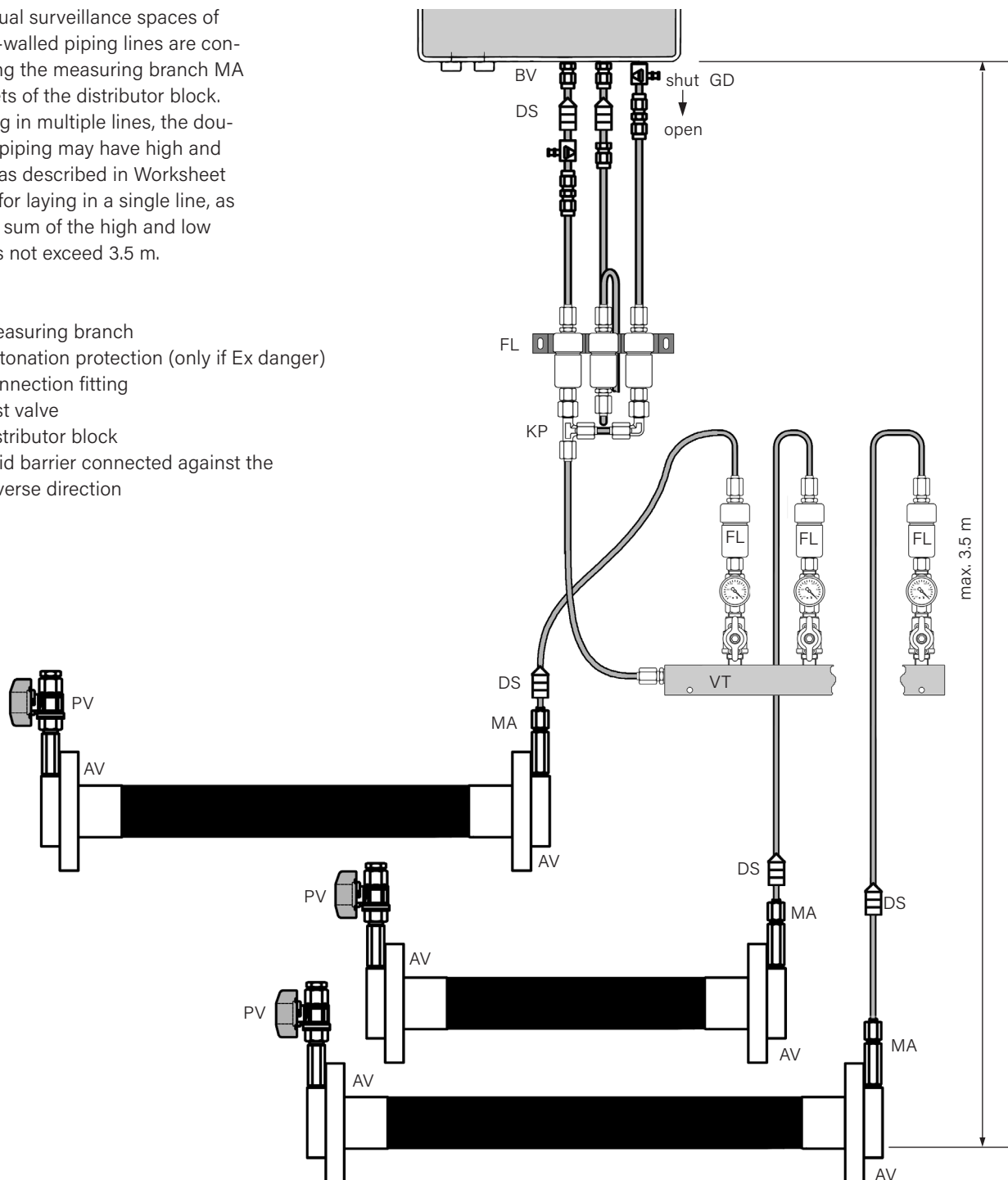

Leak monitoring systems

# Positive pressure leak detector type DLR-G ... PM

## System description

The positive pressure leak detector type: DLR-G ... PM is suitable as per approval for monitoring double-walled piping through which water-hazardous fluids with a flashpoint below and above 55 °C is transported.

### Functioning principles

The necessary pressure in the surveillance space of the double-walled piping depends on the actual operating pressure in the medium pipe (inner pipe) and is generated

- by topping up regulated by pressure changes from a stationary nitrogen pressure reservoir connected continuously to the surveillance space: **Operating Mode C** (continuously)
- from a mobile pressure reservoir which is only connected when the line is put into operation or during a function test: **Operating Mode I** (interval)

Operating modes C and I can be chosen by adjusting the switch on the board in the leak detector.

The surveillance space is connected with the leak detector by means of the connecting leads. The pressure which builds up is measured by the pressure sensor. If pressure drops to the value set previously for ALARM-ON due to a leak, the optical and acoustic alarm will be triggered.

In operating mode C the monitoring pressure is regulated after putting the system into operation by pressure changes which top up from a stationary nitrogen pressure reservoir which is continuously connected with the surveillance space and equipped with a pressure reducing valve.

In operating mode I the monitoring pressure (TOP-UP OFF) is set just once when the system is put into operation by a pressure reservoir which is not continuously connected. There is no top-up regulated by pressure changes in subsequent operation. Any drop in pressure which reaches the ALARM ON point and triggers the alarm must then be compensated by connecting the pressure reservoir till the previously set TOP-UP OFF level is reached.

The manufacturer of the leak detector stipulates that the leak detector must be undergo a maintenance check once a year on a recurring basis by an expert firm accredited according to WHG in order to ensure correct functioning and operating safety.

Switching pressures see Table 1 in Worksheet LDS 8.301.

### Technical basis

The scope of application of the leak monitoring system is limited by maximum piping lengths. The alarm is triggered by the leak detector at the latest when a pressure which is at least 1.0 bar over the maximum transport pressure of the medium pipe (inner pipe) is reached (see Table 1). The types of laying are illustrated in Worksheets LDS 8.304 and LDS 8.305.

### Tips for installation

The leak detector may not be installed in explosion-proof areas. The installation of the leak detector can be inside closed, dry rooms or outside of buildings.

### Installation/commencement of operations/operation/function testing

Detailed descriptions can be seen from the approval documentation of the DLR-G ... PM leak detector and the Worksheets for the FLEXWELL® piping. The conditions set out in the approval for the double-walled piping and the DLR-G ... PM leak detector must be complied with.

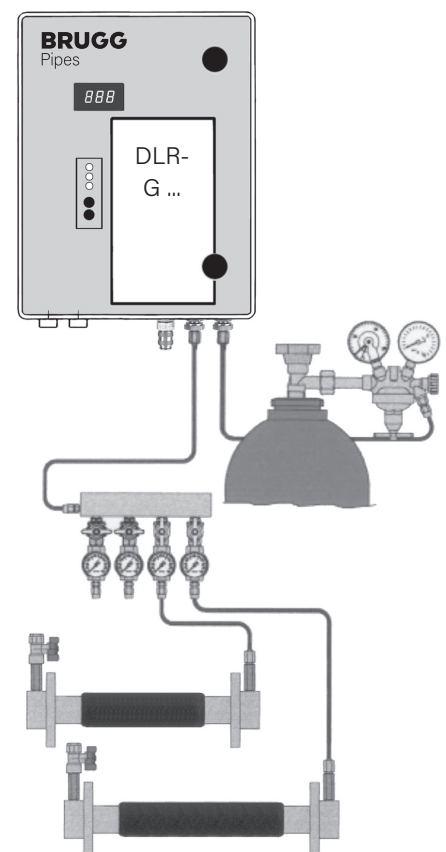

Positive pressure leak monitoring for horizontal and vertical laying and two- and multiple line systems

Leak monitoring systems

**Positive pressure leak detector type DLR-G ... PM**

Switching pressures

**Table 1: Switching pressures for operating pressures in the medium pipe**

Type DLR-G ... PM	$P_B$ bar	$P_{AE}$ bar	$P_{PA}$ bar	$P_{UDV1}^{1)}$ bar	$P_{PRÜF}$ bar	$P_{DM}$ bar	DM bar
1	pressure 0	> 1	< 2	$9.0 \pm 0.35$	> 3.4	2.5	
2	< 1	> 2	< 3	$9.0 \pm 0.35$	> 4.5	3.5	
3	< 2	> 3	< 4	$9.0 \pm 0.35$	> 5.6	4.5	
4	< 3	> 4	< 5	$9.0 \pm 0.35$	> 6.7	5.5	10
5	< 4	> 5	< 6	$9.0 \pm 0.35$	> 7.8	6.5	
6	< 5	> 6	< 7	$9.0 \pm 0.35$	> 8.9	7.5	
7	< 6	> 7	< 8	$9.0 \pm 0.35$	> 10	8.5	
10	< 9	> 10	< 12	$21.3 \pm 0.20$	> 15.4	13	
11	< 10	> 11	< 13	$21.3 \pm 0.20$	> 16.5	14	16
12	< 11	> 12	< 14	$21.3 \pm 0.20$	> 17.6	15	
13	< 12	> 13	< 15	$21.3 \pm 0.20$	> 18.7	16	
14	< 13	> 14	< 16	$21.3 \pm 0.20$	> 19.8	17	20
15	< 14	> 15	< 17	$21.3 \pm 0.20$	> 20.9	18	
16	< 15	> 16	< 18	$21.3 \pm 0.20$	> 22.0	19	
17	< 16	> 17	< 19	$21.3 \pm 0.20$	> 23.1	20	
18	< 17	> 18	< 20	$21.3 \pm 0.20$	> 24.2	21	30
21	< 20	> 21	< 23	-	> 27.5	24	
23	< 22	> 23	< 25	-	> 29.7	26	

$P_B$  = Maximum operating pressure in inner pipe (transport pressure + back pressure + pressure due to geodetic height differences)

$P_{AE}$  = switching level "Alarm ON", the alarm is triggered at the latest when this level is reached

$P_{AA}$  = switching level "Alarm OFF", when this level is exceeded the alarm signal is deleted  
( $P_{AA} = P_{AE} + \sim 250$  mbar with DLR-G 1...7;  $P_{AA} = P_{AE} + \sim 500$  mbar with DLR-G 10..18)

$P_{PA}$  = switching level "Top-Up OFF" (= set pressure level)

$P_{PE}$  = switching level "Top-Up ON" ( $P_{PE} = P_{PA} - \sim 250$  mbar with DLR-G 1...7;  
 $P_{PE} = P_{PA} - \sim 500$  mbar with DLR-G 10..18)

$P_{UDV1}$  = trigger pressure of pressure control valve 1 (from monitoring firm)

$P_{PRÜF}$  = minimum testing pressure in surveillance space

$P_{DM}$  = pressure set in pressure reducing valve

DM = pressure range set in pressure reducing valve (secondary pressure)

Leak monitoring systems

**Positive pressure leak detector type DLR-G ...**

Overview, technical data, construction

Application	Leak detector type DLR-G ... PM Operating mode C – continuously	Leak detector type DLR-G ... PM Operating mode I – intervall
Area of use	water-hazardous fluids <b>underground and surface-laid</b> double-walled piping	water-hazardous fluids <b>underground</b> double-walled piping
Monitorable pipe length	single monitorable pipe length see worksheet LDS 8.130 or sum of all pipe lengths L max. = 2000 m	single monitorable pipe length see worksheet LDS 8.130 or sum of all pipe lengths L max. = 2000 m
Electric connection	leak detector: 230 V, 50 Hz AC distributor block 1, 2 potential-free relay contacts "Alarm" 230 V, 2 A – distributor block 11, 12	leak detector: 230 V, 50 Hz AC distributor block 1, 2 potential-free relay contacts "Alarm" 230 V, 2 A – distributor block 11, 12
Leak detection	nitrogen	nitrogen
Installation area	Install inside a closed, dry room with no access for unauthorized personnel or outside buildings. Installation in explosion-proof areas is not permitted.	Install inside a closed, dry room with no access for unauthorized personnel or outside buildings. Installation in explosion-proof areas is not permitted.
Generation of extra pressure	Pressure reservoir (bottle) with pressure reduction	Nitrogen bottle with pressure reduction valve for operation or function test, mobile
Extra functions	via potential-free relay	via potential-free relay
Additional criteria	LAZ technically adapted to operating pressure of doublewalled piping	LAZ technically adapted to operating pressure of doublewalled piping
Housing dimensions	height width depth 280 mm 230 mm 130 mm	height width depth 280 mm 230 mm 130 mm
Fittings	distributor block type HMB, 2 – 8 connections to double-walled piping Insulator type ET to separate the metal connection in earthed installations acc. to TRbF 521	distributor block type HMB, 2 – 8 connections to double-walled piping Insulator type ET to separate the metal connection in earthed installations acc. to TRbF 521

**Construction Positive pressure leak detector type DLR-G ... PM**

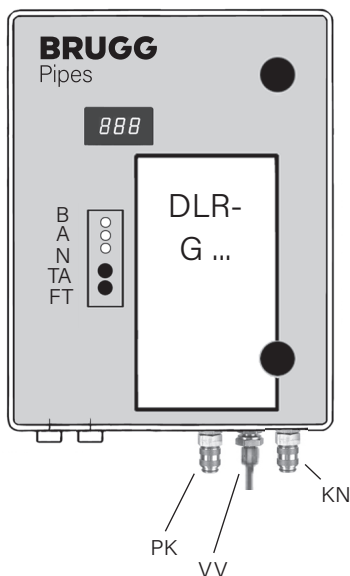

- B LED "Operation", green
- A LED "Alarm", red
- N LED "Top-up", yellow
- FT fill button
- TA switch "acoustic alarm signals"
- PK test coupling
- VV screw connection connection pipe
- KN coupling to top-up feed

Article	Article No.
DLR-G 1 – 7	1090107
DLR-G 10 – 18	1090108
DLR-G 21 M	1015838
DLR-G 23 M	1015840

Leak monitoring systems

**Positive pressure leak detector type DLR-G ...**

Single-line system – horizontal and vertical laying

The necessary working pressure in the surveillance space is generated and maintained by pressure-regulated topping-up from a stationary nitrogen pressure reservoir continuously connected to the surveillance space (Operating mode C) or a mobile pressure reservoir which is only connected when putting into operation or for function tests (Operating mode I). All permanently installed connections consist of 6 x 1 mm stainless steel piping or 8 x 1 mm PA hose with flanged screw connections. A test valve must be installed at one end of the single-line piping.

The leak detectors must be adjusted to either Operating mode C or I, as well as for the differing transport pressures of the medium pipes.

Laying: underground, surface and combined

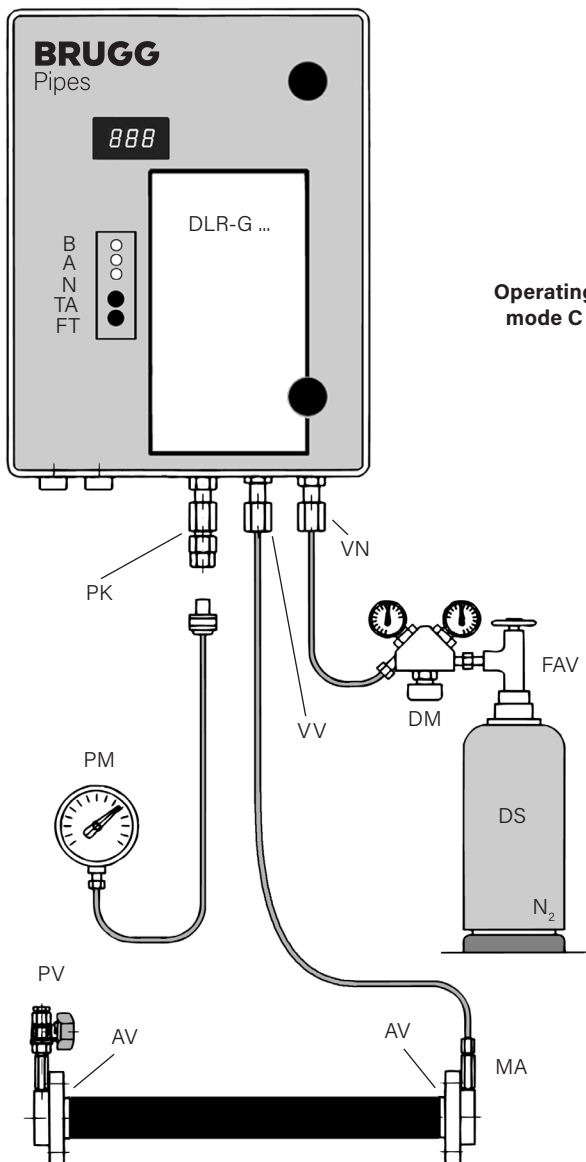

Operating mode C

**Operating mode C**

- VN screw connection top-up feed
- VV screw connection connection pipe
- DM pressure reducing valve (manufacturer BRUGG)
- FAV cut-off valve bottle
- DS pressure reservoir
- AV connection fitting
- MA measuring branch
- PV test valve
- B LED "Operation", green
- A LED "Alarm", red
- N LED "Top-up", yellow
- FT fill button
- TA switch "acoustic alarm signals"
- PK test coupling
- PM test measuring gauge

**Operating mode I**

- KN coupling to top-up feed

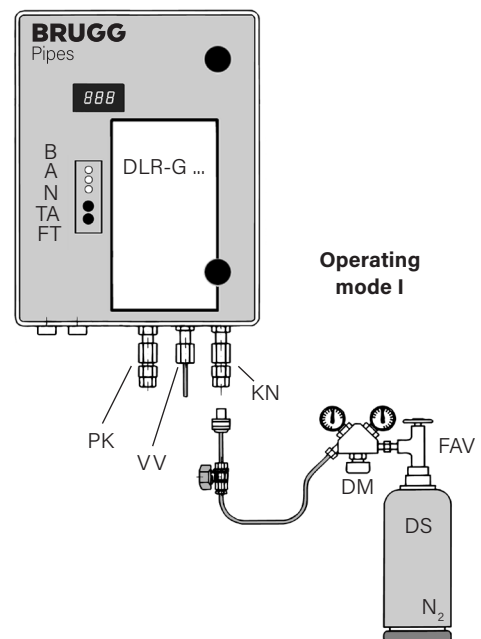

Operating mode I

Leak monitoring systems

**Positive pressure leak detector type DLR-G ... PM**

Two- and multiple line system – horizontal and vertical laying

The system functions similarly to the single-line system as per Worksheet LDS 8.304. The connection piping 6 x 1 mm stainless steel tubing or 8 x 1 mm PA hose from the leak detector to the double-walled piping are laid either via a distributor block type HMB as per Worksheet LDS 8.341 or with soldered T-fittings. The distributor block has 1 input and 2 – 8 outlets. The outlets can be closed by means of a stopcock. When it is open, the stopcock must be secured with a seal before being put into operation. A manometer for each outlet shows the pressure of the double-walled piping (stopcock closed) or of the system (stopcock open). A test valve must be installed at each end of the parallel connected piping.

Laying: underground, surface and combined

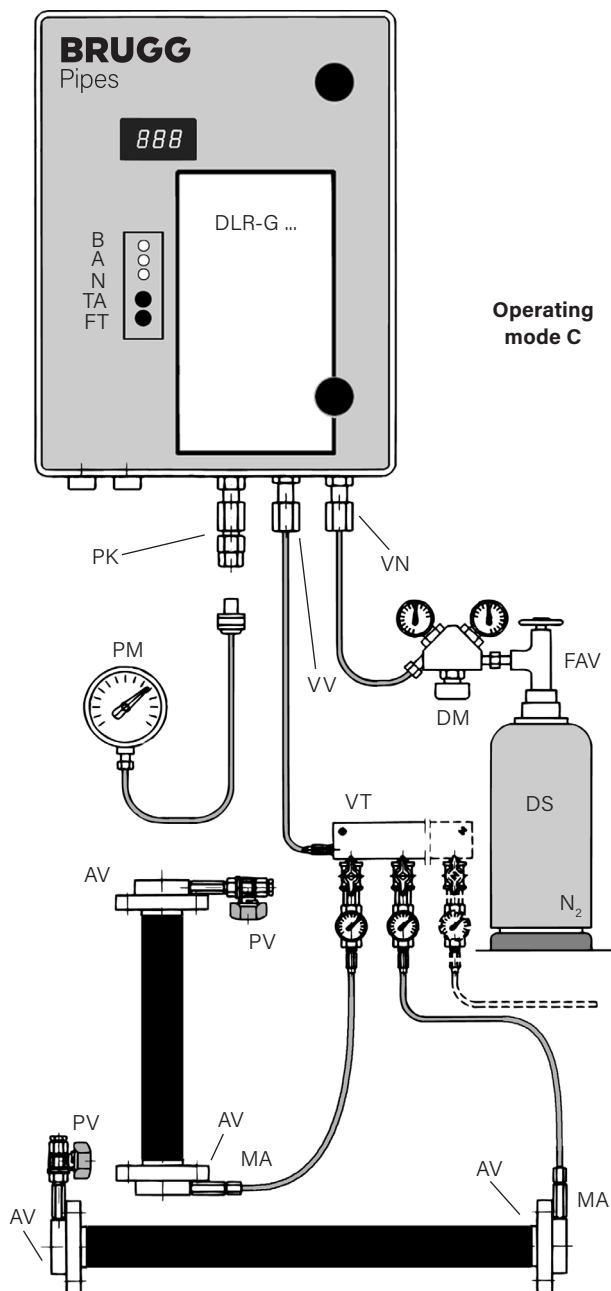

**Operating mode C**

**Operating mode C**

- VN screw connection top-up feed
- VV screw connection connection pipe
- DM pressure reducing valve (manufacturer BRUGG)
- FAV cut-off valve bottle
- DS pressure reservoir
- AV connection fitting
- MA measuring branch
- PV test valve
- B LED "Operation", green
- A LED "Alarm", red
- N LED "Top-up", yellow
- FT fill button
- TA switch "acoustic alarm signals"
- PK test coupling
- VT distributor block
- PM test measuring gauge

**Operating mode I**

- KN coupling to top-up feed

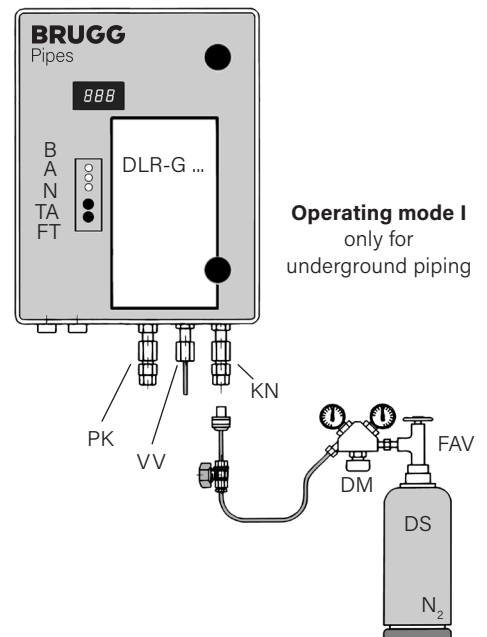

**Operating mode I**  
only for underground piping

## Leak monitoring systems

# Positive pressure leak detector type DLR-P 2.0

## System description

The positive pressure leak detector type DLR-P 2.0 is suitable for monitoring double-walled piping through which water-hazardous fluids with a flashpoint below and above 55 °C are transported.

### Principle of functioning

The necessary positive pressure in the surveillance space of the double-walled piping depends on the actual operating pressure in the medium pipe (inner pipe) and is generated by topping up regulated by pressure changes from a pump unit integrated into the leak detector. A dry filter is connected ahead of the pump, which dries the ambient air drawn in down to 10 % relative humidity. The surveillance space is connected with the leak detector DLR-P 2.0 via the connection pipes.

The pressure generated is measured and regulated by means of a pressure-operated switch. After putting the system into operation topping up is regulated by pressure changes. The integrated pump switches in to do this as soon as the pressure in the surveillance space drops somewhat, e.g. due to thermal influences. If the pressure drops to the ALARM ON level, the optical and acoustic alarm signal is triggered.

### Technical basis

The alarm is triggered at the latest when a pressure which is at least 1.0 bar over the maximum transport pressure of the medium pipe (inner pipe) is reached. The types of laying are illustrated in Worksheets LDS 8.304 and LDS 8.305.

### Tips for installation

The leak detector may not be installed in explosion-proof areas. Wherever possible, the leak detector should be installed inside an enclosed dry and frost-free room with no access for unauthorized personnel. Please use a weatherproof metal housing for installation outside of buildings.

### Installation/commencement of operations/operation/function testing

A detailed description can be seen from the approval documentation of the DLR-P 2.0 leak detector and the Worksheets for the double-walled piping.

### Normal operation

The normal operational condition is reached when the system is put into operation after the pressure has built up to the previously set level. The pressure in the surveillance space is monitored in the leak detector via a pressure-operated switch. Any leaks which may occur lead to a pressure drop.

Alarm trigger level: ON > 2.0 bar

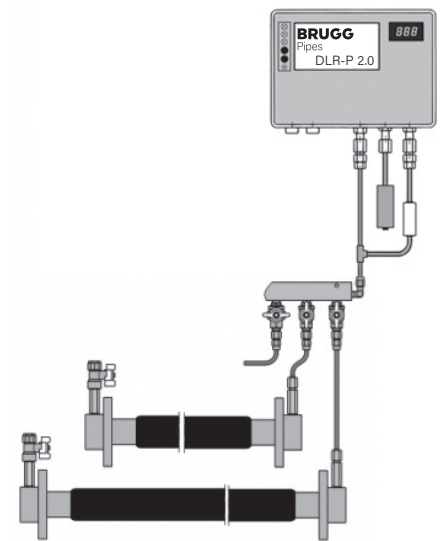

Positive pressure leak monitoring for horizontal laying and single and multiple-line systems

Leak monitoring systems

# Positive pressure leak detector type DLR-P 2.0

Overview, technical data, construction

Application	Positive pressure LD type DLR-P 2.0
Area of use	water-hazardous fluids with a flashpoint > 55 °C and < 55 °C
Monitorable pipe length	single monitorable pipe length for all SECON®-X sizes up to 500 m or sum of all pipe lengths L max. = 2000 m
Electric connection	230 V, 50 Hz AC power supply 1/2 potential-free contacts ALARM 230 V, 16 A maximum distributor block 11/12
Installation	Wherever possible, install inside a closed, dry room with no access for unauthorized personnel. Installation in explosion-proof areas is not permitted.
Extra pressure	integrated pump in leak detector
Extra functions	via potential-free relay, contacts 11 + 12
Additional criteria	leak detector adapted to the operating pressure of double-walled piping
Housing dimensions	height    width    depth 210 mm   260 mm   110 mm
Fittings	Distributor block, 2 – 8 connections to double-walled piping. Insulator type ET to separate the metal connection in earthed installations acc. to TRbF 521

## Construction positive pressure leak detector type DLR-P 2.0

Article No. 1014357

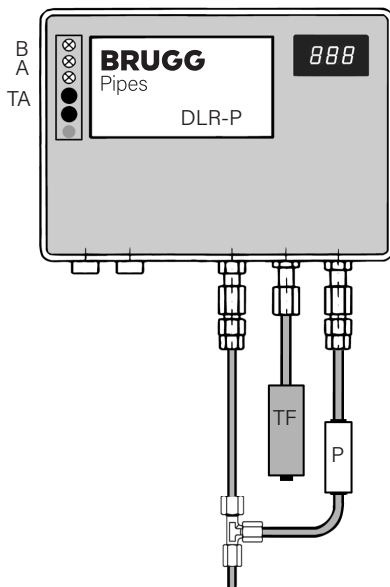

- B "Operation", green
- A "Alarm", red
- TA switch "acoustic alarm"
- TF dry filter
- P shock absorber

Leak monitoring systems

**Positive pressure leak detector type DLR-P 2.0**

Horizontal laying with a gradient to the tank

**Leak detector type DLR-P 2.0 - pressureless double-walled piping**

The necessary positive pressure in the surveillance space is generated by the pump integrated into the leak detector. The monitoring medium is air which is dried down to a relative humidity of 10 % by a dry filter connected ahead of the pump. The drying material (colourless) must be replaced when used up or regenerated (new (orange) drying material).

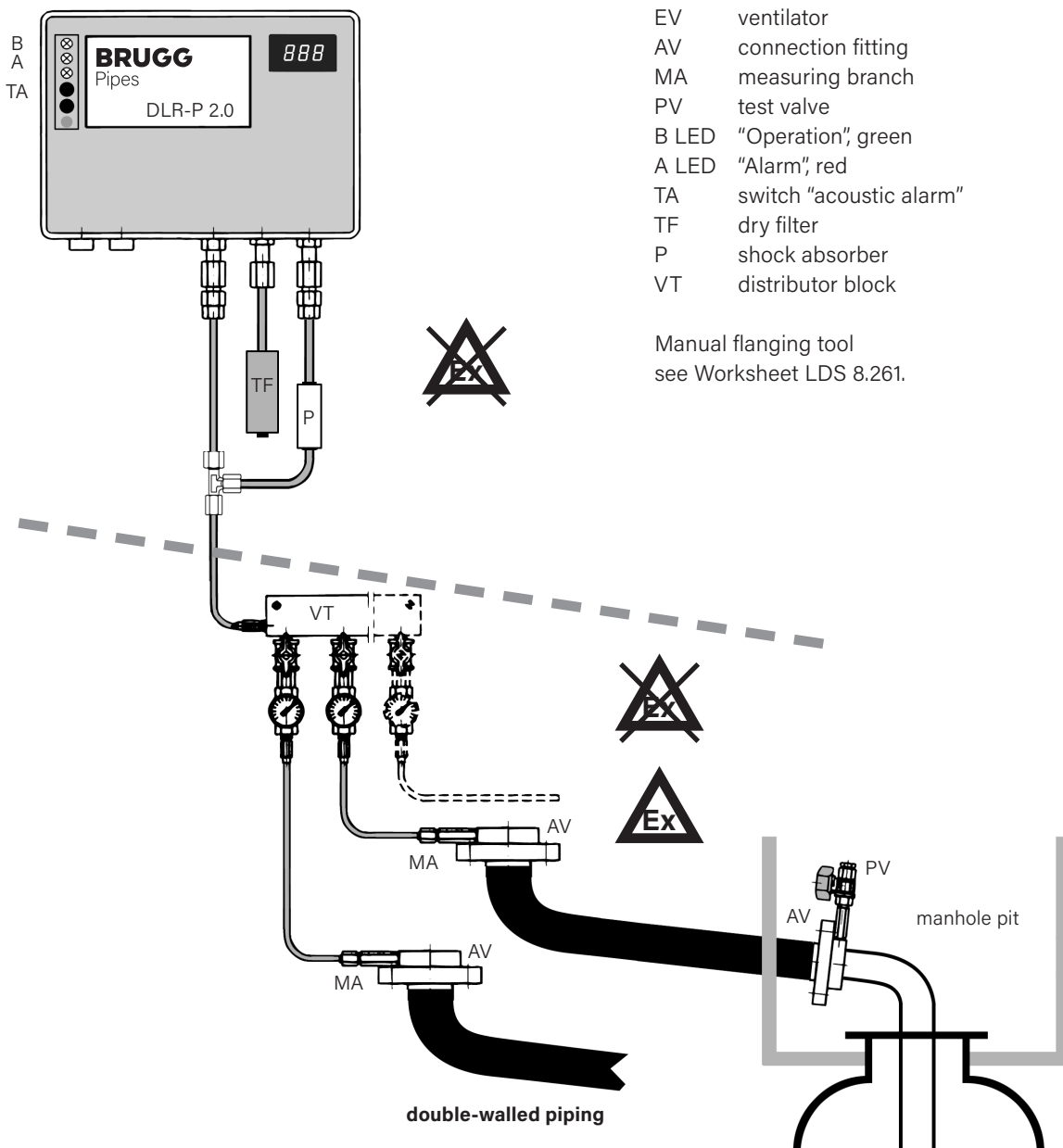

Leak monitoring systems

## Fittings for leak monitoring

Insulator, flanged adapter to hose, test valves

### Insulating piece type ET with flanged screw connection, connections stainless steel

for connecting 6 x 1 mm stainless steel pipe, to separate the metal connection in earthed installations acc. to TRbF 521

Article No. 1015580

### Insulating piece type ET with flanged screw connection, connections galvanized steel

for connecting 8 x 1 mm PA hose to separate the metal connection in earthed installations acc. to TRbF 521. Two flanged adapters to the hose are needed (not shown here, similar to flanged screw connector with stainless steel connections).

Article No. 1015579

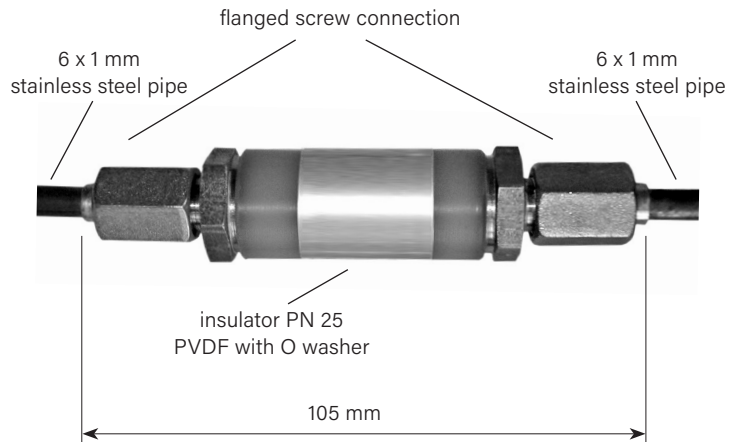

### Flanged adapter to hose

for connecting to 8 x 1 mm PA hose on flanged screw connection.

Flanged adapter – Article No. 1017991

PA hose\* – Article No. 1017992

\*PA hose is not UV-resistant.

If necessary, use with a protective conduit.

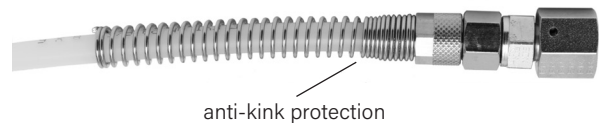

### Test valve type PV, long

for connection fitting with split loose flange

#### Material

Steel: Article No. 1015854

Stopcock – brass, nickel-plated

Long nipple – galvanized steel, chromated

Stainless steel 1.4571 complete: Article No. 1015853

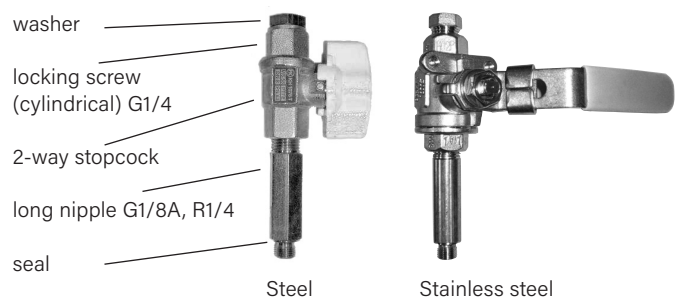

### test valve type PV, short

for connection fitting with external thread or welded end

#### Material

Steel: Article No. 1015855

Stopcock – brass, nickel-plated

Nipple – galvanized steel, chromated

Stainless steel 1.4571 complete: Article No. 1015857

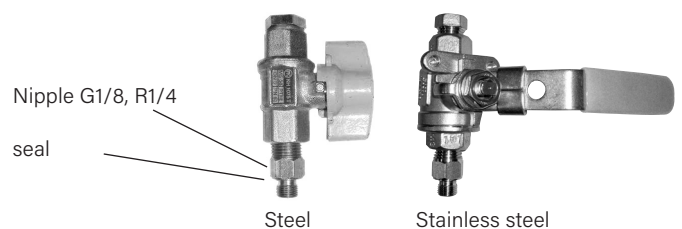

Leak monitoring systems

# Fittings for leak monitoring

## Measuring branch, manual flanging tool

**Measuring branch type MA, long**  
for connection fitting with collar and split loose flange (not shown here)

The connection fitting is shown here with a quarter cut.

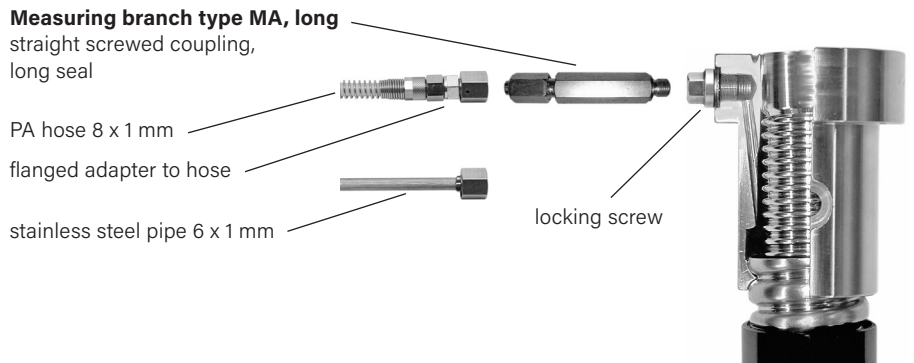

**Measuring branch type MA, short**  
for connection fitting with thread or welded end

The connection fitting is shown here with a quarter cut.

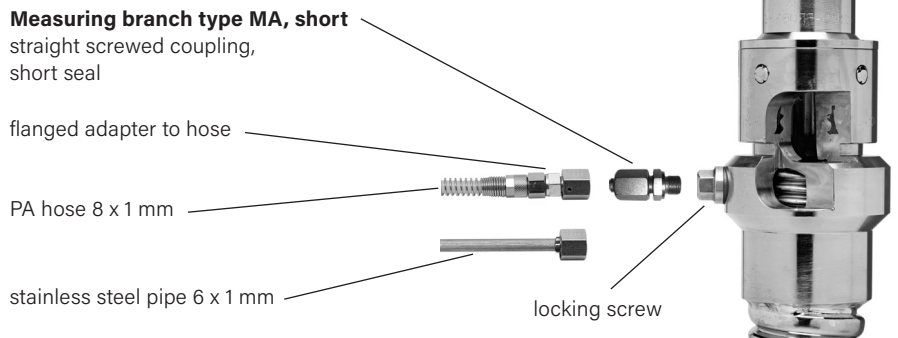

### Materials and Article Numbers

**Galvanized steel**

Measuring branch short	1015563	with PA hose* 8 x 1	1017992	and flanged adapter to hose	1017991
Measuring branch long	1015558	with PA hose* 8 x 1	1017992	and flanged adapter to hose	1017991

**Stainless steel**

Measuring branch short	1015561	with stainless steel pipe 6 x 1	1015572
Measuring branch long	1015559	with stainless steel pipe 6 x 1	1015572

### Manual flanging tool with mandrel

Article No. 1016081

For flanging 6 x 1 mm stainless steel pipe we offer the tool shown here:

**For technical reasons only the BRUGG mandrel 74° may be used for flanging the stainless steel monitoring lead!**

The BRUGG mandrel 74° is available as replacement under Article No. 1016082.

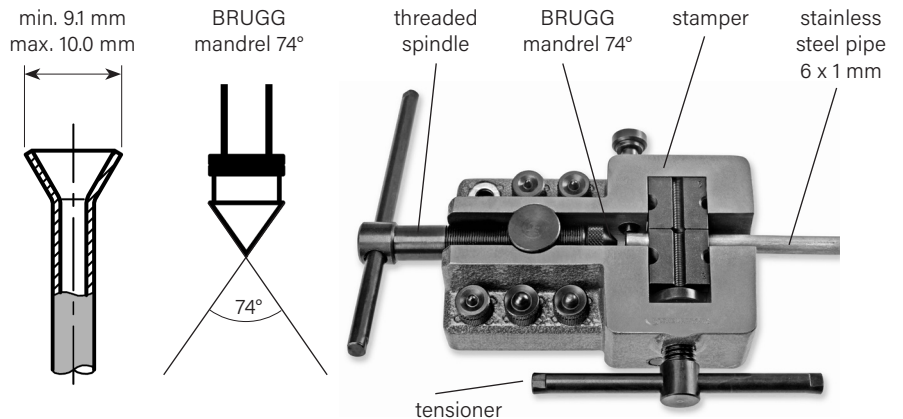

\*PA hose is not UV-resistant. If necessary, use with a protective conduit.

Leak monitoring systems

## Fittings for vacuum leak monitoring

Solenoid valve, additional measuring unit ZD 410, detonation guard, distributor block

### 2/2-way solenoid valve (for VLR 410 PMMV Si)

needed at operating pressure over 5 bar

Article No. 1090109 for 24 V

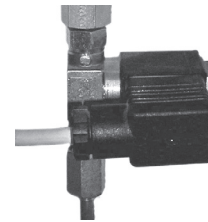

### Additional measuring unit ZD 410

Complete, incl. three-way test stopcock

Dimensions (H x W x D): 200 x 120 x 100 mm

Article No. 1015785



### Detonation guard

for installation in explosion-threatened areas

Stainless steel: Article No. 1015783



### Distributor block type HM-1B for vacuum

Type	Connections	L	Article No. mm
2 HM-1B	2	80	1015776
3 HM-1B	3	130	1015777
4 HM-1B	4	180	1015778
5 HM-1B	5	230	1015779
6 HM-1B	6	280	1015780
7 HM-1B	7	330	1015781
8 HM-1B	8	380	1015782

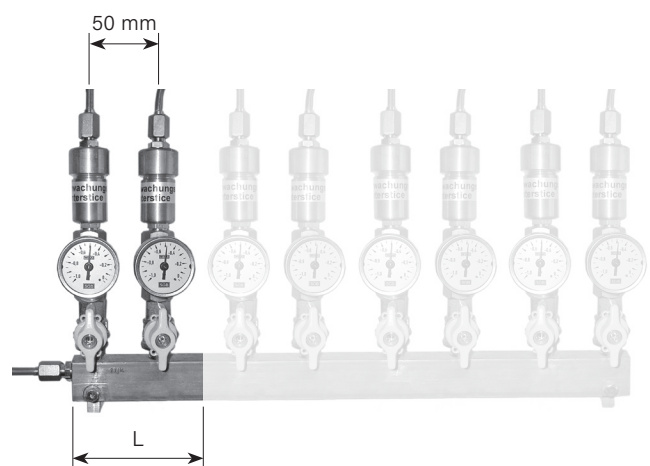

Leak monitoring systems

## Fittings for positive pressure leak monitoring

Fittings for positive pressure leak detector type DLR-G ... PM

### Pressure reducing valve for nitrogen bottle

Type of gas: nitrogen  
 Primary pressure: 200 bar  
 Back pressure: 10 / 16 / 20 / 22 bar

Type	Back pressure	Article No.
DM 10	10 bar D	1015846
DM 16	16 bar D	1015848
DM 20	20 bar D	1015849
DM 30	30 bar D	1056290
DM 10 NA	10 bar NL	1015851
DM 10 FA	10 bar F	1015847

German connection not marked

NA = Dutch connection

FA = French connection

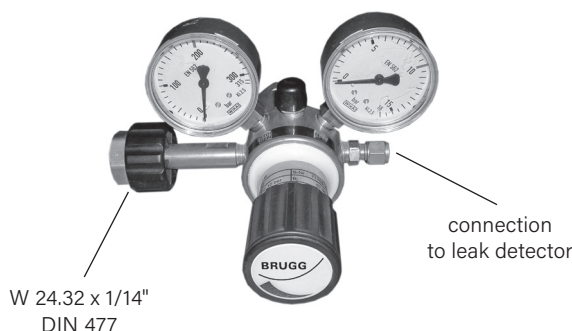

### Nitrogen-steel cylinder type 12

N<sub>2</sub>-F (10 litres) filling pressure 200 bar (without engraving)  
 Article No. 1015843

Wall bracket for nitrogen cylinder type 12

Article No. 1015845



### Connection with flare type fitting

for mobile topping-up DLR-G (Operating mode I)

Article No. 1015842



### Distributor block type HMB with flanged screw

Connection material: brass

The distributor block is available with from 2 up to max. 8 connections.

Type	Connections	L mm	DLR-G ... PM with manometer 0 - 16 bar Article No.
2 HMB	2	80	1015803
3 HMB	3	130	1015804
4 HMB	4	180	1015805
5 HMB	5	230	1015806
6 HMB	6	280	1015807
7 HMB	7	330	1015808
8 HMB	8	380	1015809

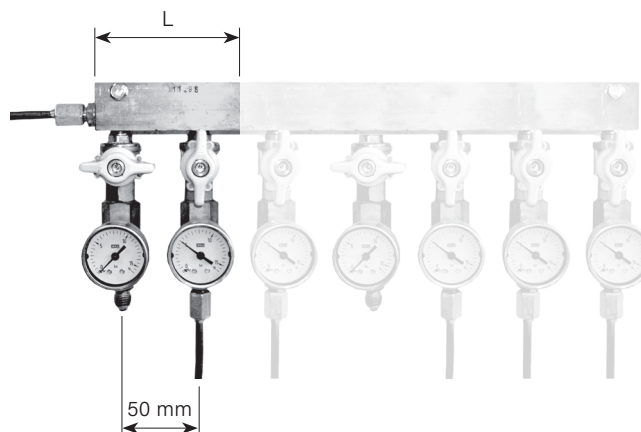

Leak monitoring systems

## Fittings for leak monitoring

Fittings for positive pressure leak detector type DLR-P 2.0

### Distributor block type HMB with flanged screw connection

Material: brass

The distributor block is available with from 2 up to max. 8 connections.

Type	Connections	L mm	DLR-P 2.0 with manometer 0 - 4 bar Article No.
2 HMB	2	80	1015810
3 HMB	3	130	1015811
4 HMB	4	180	1015812
5 HMB	5	230	1015813
6 HMB	6	280	1015814
7 HMB	7	330	1015815
8 HMB	8	380	1015816



### Dry filter TF 200 incl. drying agent and holder

Article No. 1014356



## Leak monitoring systems

**Leak monitoring: Checking the plant**

## Procedure

**Test requirements**

The basic safety technical requirements are set out in the Technical Rules for flammable Fluids – TRbF/TRBS. The legal provisions governing water usage are governed by the German Water Resources Act (Wasserhaushaltsgesetz – WHG) and the ordinance dealing with plants which handle water-hazardous substances - VVAwS – as well as the regulations implementing the VVAwS.

**Standard procedures for testing TRbF 620 8 (technical rules for flammable fluids)**

Standard procedures for tanks and piping

Section 1.23 Double-walled piping

- (1) No. 1.21 applies. Connections (see Number 1.21, Par. 5) do not need to be exposed for the pressure test however.
- (2) In as far as no connections to the double-walled piping are made on site, the construction and pressure test by the technical expert can be dispensed with.
- (3) The test pressure for the test on the surveillance space depends on that given in the approval for the leak detector. A pressure test of the inner pipe is not necessary if the test pressure for the surveillance space is at least that for the inner pipe and a certificate from an expert firm can be provided for the construction and pressure test of the inner pipe.

**Tightness test**

The double-walled piping is prefabricated and tested at the factory. If piping configured and put together ex works is used, Pos. (2) applies. If the pipes are laid in one piece, as is the general rule, the tightness of the connection fittings installed on site must be tested with test pressure in the surveillance space.

The level of test pressure depends on the leak detector which is connected and in the case of

- a vacuum leak detector is max. operational piping pressure x 1.3, but at least 5 bar
- with a positive pressure leak detector max. monitoring pressure in the surveillance space x 1.3, but at least 5 bar.

The construction of the connection fittings, their material and joining methods are a system component of the approval. They comply with the most recent regulations. The pressure test of the inner pipe is not necessary since the double-walled piping has already undergone a tightness test at the factory.

**Acceptance test, repeat testing**

The acceptance test or the repeat tests are dealt with in Section 2 of the TRbF 620. According to this, the tightness test for the double-walled piping with a leak detector is replaced by a function test of the leak detector equipment.

The test intervals are set out in the VVAwS. Repeat tests are to be carried out after 5 years (in protected areas after 2.5 years).

§§ 62/63 WHG also refers to the need to comply with the legislation of the Federal State involved. In the regulations for plants - VVAwS -, here, e.g. in Bavaria, it stands in Par. 18.1 of the VVAwS that leak detectors must be subjected to a function test at least once a year. The function test is to be carried out by specialist personnel or by an accredited expert firm.

## Leak monitoring systems

# Leak monitoring: Checking the plant

## Procedure

### Testing the leak monitoring system

After it has been installed and put into operation as well as following maintenance work, a check must be made on the leak monitoring system/leak detector to ascertain whether it functions as foreseen and safely. The check must also include a test of free passage in the suction or positive pressure tubing and in the measuring lead between leak detector and surveillance space as well as the test valves. The complete plant (surveillance space with connection pipes and leak detector) must be tested for tightness by connecting a measuring device with an accuracy of at least Class 1.6 to the test sockets of the leak detector.

The operating and functional safety of the leak detector in its mechanical-pneumatic and electrical part must be determined by measuring the switching values of the vacuum or positive pressure switch and by checking the transport level of the regulating pump set out in the documentation of the leak detector. The pressure rise or drop in the surveillance space are to be measured via the test fitting on the leak detector. In this way the free passage test of connection pipes (suction or positive pressure tubing and the measuring lead) is also given. The triggering of the optical and acoustic alarm signals by the leak detectors must also be determined.

The fittings and accessory components necessary and prescribed for the operation of the leak monitoring device (e.g. dry filter, fluid barriers, condensate containers) are also to be tested for functional and operational safety.

A tests report must be drawn up on the test of the leak monitoring device.

The further Worksheets give details of the systematic checking procedures for the systems of the various leak monitoring devices.

Double-walled piping with vacuum leak detector

Double-walled piping with positive pressure leak detector

Any defects in the leak monitoring system which cannot be rectified during the check must be mentioned in the test report. The plant operator must be explicitly informed of such findings. The plant operator shall receive a copy of the test report, another goes to the specialist firm and is kept there.

The manufacturer of the leak detector prescribes a maintenance check of the leak detector repeated every year by a specialist firm acc. to §§ 62/63 WHG in order to ensure functional and operational safety.

Leak monitoring systems

### Leak monitoring: Checking the plant

Vacuum leak detector type VLR 410 PMMV Si, VLR 410/E and VLX 330/A-Ex – General information

Project: \_\_\_\_\_

Contact person: \_\_\_\_\_

Telephone: \_\_\_\_\_ eMail: \_\_\_\_\_

Leak detector type: VLR 410 PMMV Si  VLR 410/E  VLX 330/A-Ex

Double-walled piping type: \_\_\_\_\_

No. of piping lines: \_\_\_\_\_ overall length: \_\_\_\_\_ m

Surveillance space volume: \_\_\_\_\_ m<sup>3</sup>

Transport medium: \_\_\_\_\_

Operating pressure: \_\_\_\_\_

Device under seal: yes  no

**Positions when checking the plant - Checklist see Worksheet LDS 8.273**

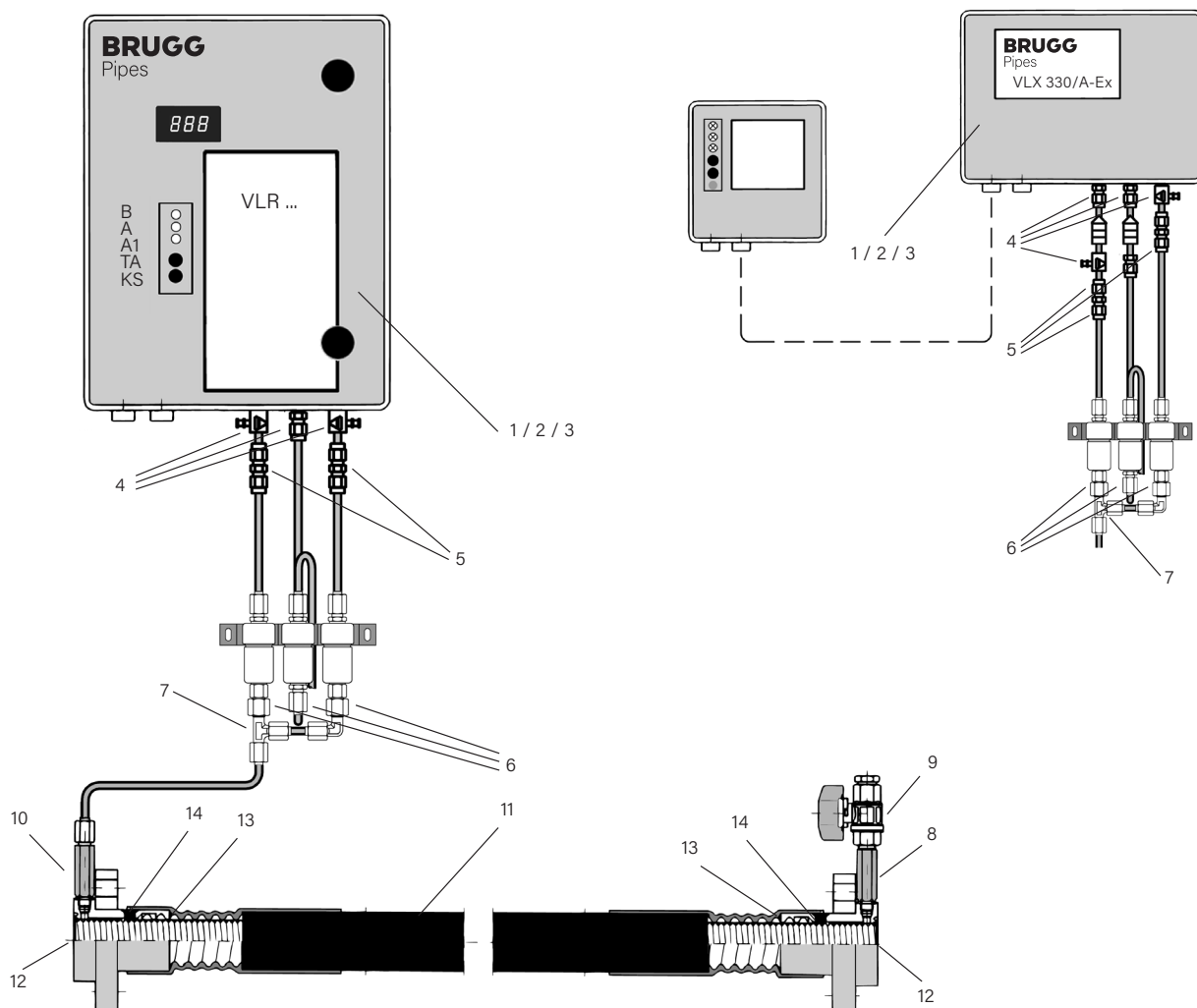

Leak monitoring systems

### Leak monitoring: Checking the plant

Vacuum leak detector type VLR 410 PMMV Si, VLR 410/E and VLX 330/A-Ex – Checking the plant

Pos No.	of component to be checked	functions well	defective
1	Vacuum pump	<input type="checkbox"/>	<input type="checkbox"/>
2	Vacuum switch Switching levels: VLR 410 PMMV Si and VLR 410/E / VLX 330/A-Ex pump "off" < 540 mbar / < 540 mbar pump "on" the level must be at least 15 mbar higher than the switching level measured for "Alarm on" Alarm "on" > 410 mbar / > 330 mbar	<input type="checkbox"/>	<input type="checkbox"/>
3	Filter with non-return valve	<input type="checkbox"/>	<input type="checkbox"/>
		<b>tight</b>	<b>untight</b>
4	Screw connections: ventilation screw and three-way stopcock	<input type="checkbox"/>	<input type="checkbox"/>
5	Screw connections underneath the leak detector	<input type="checkbox"/>	<input type="checkbox"/>
6	Screw connections: fluid barriers	<input type="checkbox"/>	<input type="checkbox"/>
7	T-piece in the connection pipes – single-line system – *	<input type="checkbox"/>	<input type="checkbox"/>
8/9	All screw connections: long nipple/test valve	<input type="checkbox"/>	<input type="checkbox"/>
10	All screw connections: measuring branch	<input type="checkbox"/>	<input type="checkbox"/>
11	Pressure test of individual lines: surveillance space	<input type="checkbox"/>	<input type="checkbox"/>
	<b>When piping is untight</b>		
12	Screw socket, inner weld seams / GRAPA	<input type="checkbox"/>	<input type="checkbox"/>
13	Screw socket, outer weld seams / GRAPA	<input type="checkbox"/>	<input type="checkbox"/>
14	Screw socket, all fitting drill holes	<input type="checkbox"/>	<input type="checkbox"/>
	<b>Put into operation</b>	<b>yes</b>	<b>no</b>
	surveillance space – clear passag	<input type="checkbox"/>	<input type="checkbox"/>
	existing defects rectified	<input type="checkbox"/>	<input type="checkbox"/>
	Plant put into operation	<input type="checkbox"/>	<input type="checkbox"/>
	Vacuum leak detector under seal	<input type="checkbox"/>	<input type="checkbox"/>

\* also in multiple-line system with distributor block

Date: \_\_\_\_\_ Stamp/ Signature: \_\_\_\_\_

Leak monitoring systems

### Leak monitoring: Checking the plant

Vacuum leak detector type VLR 410 PMMV Si, VLR 410/E and VLX 330/A-Ex – Test report

Operator: \_\_\_\_\_ Project: \_\_\_\_\_

Test date: \_\_\_\_\_ Tester: \_\_\_\_\_ Telephone: \_\_\_\_\_

1. First commissioned  2. annual check  3. after fault repair  4. other

FLEXWELL® Safety Pipe type: \_\_\_\_\_ STAMANT type: \_\_\_\_\_ SECON®-X type: \_\_\_\_\_ Transport medium: \_\_\_\_\_

Pipe length m: \_\_\_\_\_ No. lines: \_\_\_\_\_ Laying: horizontal  vertical

Type leak detector: \_\_\_\_\_ No. of device: \_\_\_\_\_ built (year): \_\_\_\_\_

1. Test of vacuum switch  
 pump off: \_\_\_\_\_ mbar  
 pump on: \_\_\_\_\_ mbar Alarm on: \_\_\_\_\_ mbar

2. Pumping head of vacuum pump: \_\_\_\_\_ mbar

2. Pumping head sufficient: yes  no  repaired

3. Tightness of leak detector determined\*: yes  no  repaired

4. Connection pipes – kinks and crimping: yes  no  repaired

5. Clear passage through suction pipe: yes  no  repaired

6. Clear passage through measuring lead: yes  no  repaired

7. Clear passage through measuring lead: yes  no  repaired

8. Tightness of leak detector system determined\*: yes  no  repaired

9. Potential-free outlet (clamp 11/12) – funktion OK: yes  no  repaired

10. Laying with ZD – funktion OK (Alarm triggered latest at 410 mbar): yes  no  repaired

11. Control cable ZD connected to leak detector: yes  no  repaired

12. Vertical laying with solenoid valve – funktion OK: yes  no  repaired

13. Permanent power supply connection, non-detachable: yes  no  repaired

14. Alarm of leak detector OK: yes  no  repaired

15. Leak detector system functional and operationally safe: yes  no

16. Leak detector system as per approval: yes  no

17. Leak detector under seal: yes  no

Remarks: \_\_\_\_\_

Date: \_\_\_\_\_ Signature of expert: \_\_\_\_\_ Company stamp: \_\_\_\_\_

\* see Page 18, leak detector documentation VLR (must be with device)

Leak monitoring systems

# Leak monitoring: Checking the plant

## Positive pressure leak detector type DLR-G ... PM and DLR-P 2.0 – General information

**Details of procedure for checking the plant leak monitoring see Worksheets LDS 8.270**

**Leak detector**

DLR-P 2.0 n  
 DLR-G \_\_\_\_\_ PM continuously n  
 interval n

Project: \_\_\_\_\_

Contact person: \_\_\_\_\_

Telephone: \_\_\_\_\_ eMail: \_\_\_\_\_

Double-walled piping type: \_\_\_\_\_

No. of lines: \_\_\_\_\_ Overall length: \_\_\_\_\_ m

Surveillance space volume: \_\_\_\_\_ m3

Substance transported: \_\_\_\_\_

Operating pressure: \_\_\_\_\_

Device under seal:   yes            no

**Positions when checking the plant - Checklist see Worksheet LDS 8.363**

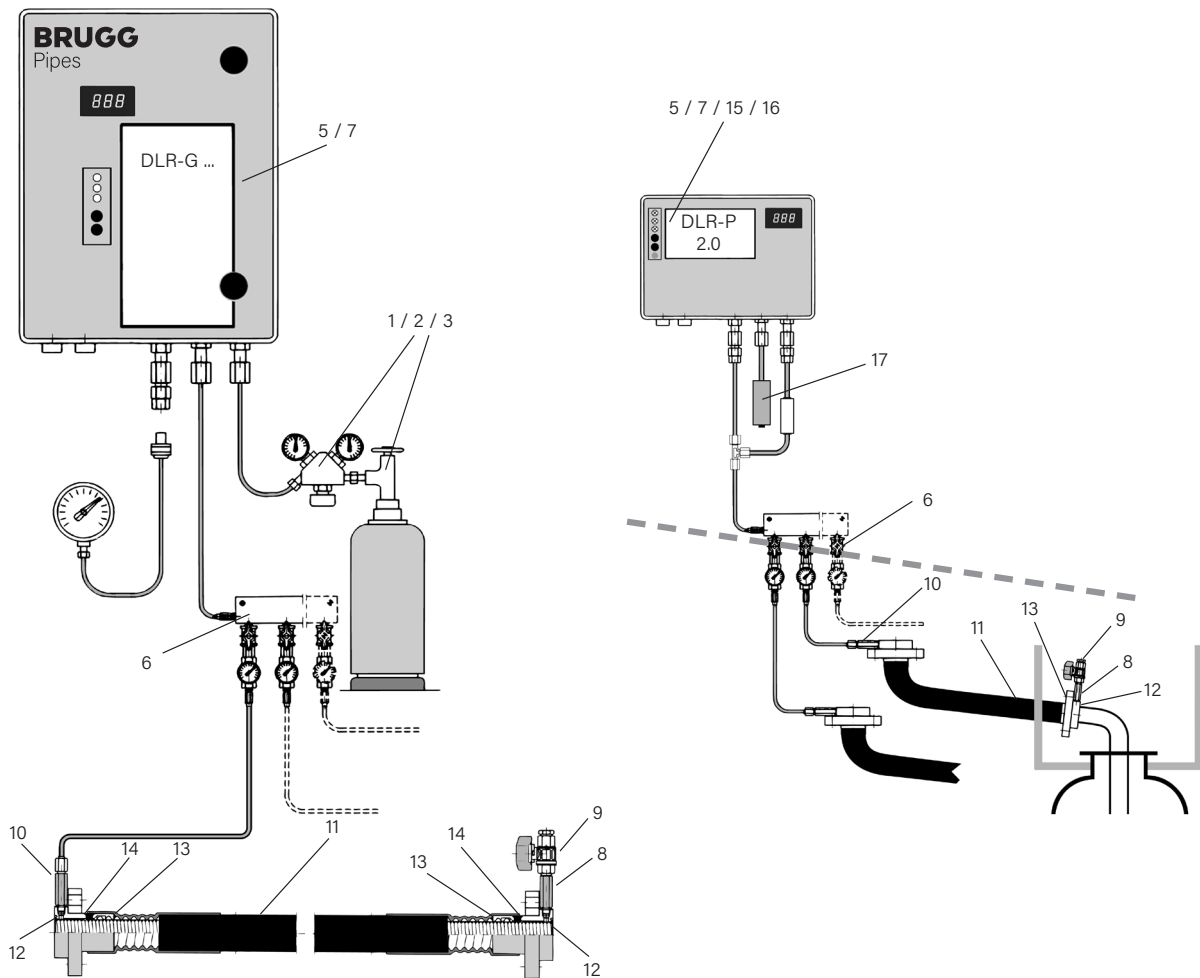

Leak monitoring systems

### Leak monitoring: Checking the plant

Positive pressure leak detector type DLR-G ... PM and DLR-P 2.0 – Checking the plant

Pos. No.	Component to be checked	tight/ functions well	untight/ defective
1	N <sub>2</sub> bottle valve: spindle/thread	<input type="checkbox"/>	<input type="checkbox"/>
2	N <sub>2</sub> pressure reducing valve: check if BRUGG type! If from another manufacturer: replace it!	<input type="checkbox"/>	<input type="checkbox"/>
3	N <sub>2</sub> pressure reducer	<input type="checkbox"/>	<input type="checkbox"/>
5	Safety valve	<input type="checkbox"/>	<input type="checkbox"/>
6	Screw connections: manometer	<input type="checkbox"/>	<input type="checkbox"/>
7	All connections: in leak detector	<input type="checkbox"/>	<input type="checkbox"/>
8/9	All screw connections: test valves	<input type="checkbox"/>	<input type="checkbox"/>
10	All screw connections: measuring branches	<input type="checkbox"/>	<input type="checkbox"/>
11	Pressure tests of ind. lines: surveillance space	<input type="checkbox"/>	<input type="checkbox"/>
	<b>When piping is untight</b>	<input type="checkbox"/>	<input type="checkbox"/>
12	Screw socket, inner weld seams / GRAPA	<input type="checkbox"/>	<input type="checkbox"/>
13	Screw socket, outer weld seams / GRAPA	<input type="checkbox"/>	<input type="checkbox"/>
14	Screw socket, all fitting drill holes	<input type="checkbox"/>	<input type="checkbox"/>
15	Positive pressure pump (only DLR-P 2.0)	<input type="checkbox"/>	<input type="checkbox"/>
16	Positive pressure switch, switching levels (only DLR-P 2.0) pump "off" < 2400 mbar pump "on" > 2300 mbar Alarm "on" > 2000 mbar	<input type="checkbox"/>	<input type="checkbox"/>
17	Dry filter (only DLR-P 2.0)	<input type="checkbox"/>	<input type="checkbox"/>
	<b>Put into operation</b>	<b>yes</b>	<b>no</b>
	Surveillance space has clear passage	<input type="checkbox"/>	<input type="checkbox"/>
	Existing defects rectified	<input type="checkbox"/>	<input type="checkbox"/>
	Plant put into operation	<input type="checkbox"/>	<input type="checkbox"/>
	Positive pressure leak detector under seal	<input type="checkbox"/>	<input type="checkbox"/>

Date: \_\_\_\_\_ Stamp/  
Signature: \_\_\_\_\_

Leak monitoring systems

### Leak monitoring: Checking the plant

Positive pressure leak detector type DLR-G ... PM and DLR-P 2.0 – Test report

Operator: \_\_\_\_\_ Project: \_\_\_\_\_

Test date: \_\_\_\_\_ Tester: \_\_\_\_\_ Telephone: \_\_\_\_\_

1. First commissioned  2. annual check  3. after fault repair  4. other

FLEXWELL® Safety Pipe type: \_\_\_\_\_ STAMANT type: \_\_\_\_\_ SECON®-X type: \_\_\_\_\_ Transport medium: \_\_\_\_\_

Pipe length m: \_\_\_\_\_ No. lines: \_\_\_\_\_ Laying: underground  surface

Type leak detector: DLR-G \_\_\_\_\_ Operating mode: continuously  interval  DLR-P 2.0

Device no.: \_\_\_\_\_ Built (year): \_\_\_\_\_

**Switching levels measured:**

$P_{AE}$ (Alarm on)	bar	$P_{PA}$ (top-up off):	bar	$P_{DM}$ (supply pressure at pressure reducing valve):	bar		
Correct levels	$P_{AE}$	$P_{PA}$	$P_{DM}$	Correct levels	$P_{AE}$	$P_{PA}$	$P_{DM}$
	bar	bar	bar		bar	bar	bar
DLR-G 1	> 1	< 2	2.5	DLR-G 12	> 13	< 14	15
DLR-G 2	> 2	< 3	3.5	DLR-G 13	> 13	< 15	16
DLR-G 3	> 3	< 4	4.5	DLR-G 14	> 14	< 16	7
DLR-G 4	> 4	< 5	5.5	DLR-G 15	> 15	< 17	18
DLR-G 5	> 5	< 6	6.5	DLR-G 16	> 16	< 18	19
DLR-G 6	> 6	< 7	7.5	DLR-G 17	> 17	< 19	20
DLR-G 7	> 7	< 8	8.5	DLR-G 18	> 18	< 20	21
DLR-G 10	> 10	< 12	13.0	DLR-G 21	> 21	< 23	24
DLR-G 11	> 11	< 13	14.0	DLR-G 23	> 23	< 25	26

1. Tightness of leak detector determined: pressure drop	bar in	min.	yes	<input type="checkbox"/>	no	<input type="checkbox"/>	repaired	<input type="checkbox"/>
2. Connection pipe – kinks and crimping:			yes	<input type="checkbox"/>	no	<input type="checkbox"/>	repaired	<input type="checkbox"/>
3. Clear passage through connection pipe:			yes	<input type="checkbox"/>	no	<input type="checkbox"/>	repaired	<input type="checkbox"/>
4. Tightness of leak detector system determined: pressure drop	bar in	min.	yes	<input type="checkbox"/>	no	<input type="checkbox"/>	repaired	<input type="checkbox"/>
5. Potential-free outlet (clamp 11/12) – Function OK:			yes	<input type="checkbox"/>	no	<input type="checkbox"/>	repaired	<input type="checkbox"/>
6. Permanent power supply connection, non-detachable:			yes	<input type="checkbox"/>	no	<input type="checkbox"/>	repaired	<input type="checkbox"/>
7. Alarm of leak detector OK:			yes	<input type="checkbox"/>	no	<input type="checkbox"/>	repaired	<input type="checkbox"/>
8. Leckanzeigesystem funktions- und betriebssicher:			yes	<input type="checkbox"/>	no	<input type="checkbox"/>		
9. Leak detector system functional and operationally safe:			yes	<input type="checkbox"/>	no	<input type="checkbox"/>		
10. Leak detector under seal:			yes	<input type="checkbox"/>	no	<input type="checkbox"/>	remark:	

Remarks: \_\_\_\_\_

Date: \_\_\_\_\_ Signature of expert: \_\_\_\_\_ Company stamp: \_\_\_\_\_

## Leak monitoring systems

# Locating the leak inner and outer pipe

## Procedure

### Leak monitoring

Flammable or water-hazardous fluids are transported through the inner medium pipe of a double-walled pipe system. The outer containment pipe prevents uncontrolled spillage of the dangerous transport medium if leaks occur. Approved leak detectors can be connected to the surveillance space between the inner and outer pipes for permanent leak monitoring with vacuum or positive pressure principle. The leak detectors regulate the monitoring pressure in the surveillance space of the double-walled safety pipe and register any pressure changes when either the inner or outer pipe is damaged. When damage occurs, the leak detector gives an acoustic or optical alarm signal which can be transmitted over long distances via potential-free relay contacts.

### Locating the leak

If the alarm is given, first of all a check should be carried out on all easily accessible and visible parts of the piping such as the leak detector, connection pipes and test valves at the end connections. The next step is to examine the weld or solder seams or the threaded/couples end connections of the visible connection fittings (inner/outer pipe).

If the leak has still not been found, the piping itself needs to be checked. It is recommended to detach all connections to further piping above ground, to install blank flanges at both ends and to mount a manometer for the inner pipe at one end. After that, the surveillance space should be pressurized and checked whether the pressure leaks out into the inner pipe or into the environment.

### The leak detector and the connection pipes

Untightness in the leak detector or in the connection pipes can be easily detected by means of a pressure test and spraying on bubble-forming fluid.

### Leaks in the outer pipe

If the outer pipe is damaged it is recommended to check whether earth-moving work has been carried out along the piping route. The majority of outer pipe damage is caused by mechanical impact from outside (e.g. by mechanical excavators). For this reason it makes sense to check for damage to the outer pipes first in such areas.

If the leak cannot be found in this way, the surveillance space between inner and outer pipe can be filled with a readily volatile gas, e.g. helium, to locate the leak. The gas escapes through the leak and rises to the surface, where it can be detected by using a gas detector. If the pipe route runs underneath a concrete or asphalt surface, holes can be drilled above the route at intervals of 1 m to 2 m.

### Leaks in the inner pipe

One of the options for locating a leak in the inner pipe is the ultrasonic method. Nitrogen, which is filled in the surveillance space, enters the inner pipe through the leak, causing a flow noise. An ultrasound sensor which then is pulled slowly through the inner pipe registers this noise and reports it to a display unit. The leak can be located by reading off the metre indication on the pulling wire of the sensor, it can then be determined how far along the pipe from the end the leak is located.



**Legend**

- Partner
- ▲ Production sites
- Branches



**BRUGG**  
Pipes