

# BRUGG

Pipes

## FLEXWELL® Safety Pipe

Pipe system for installations

Project planning

**PIONEERS IN  
INFRASTRUCTURE**



## FLEXWELL® Safety Pipe

**Contents**

	<b>Processing enquiries</b>		
<b>FSR 4.001</b>	<b>Minutes of the hearing to award the contract/giving the order</b>		
FSR 4.002			
FSR 4.003			
	<b>Datasheet FLEXWELL® Safety Pipe</b>		
	<b>Resistance of materials</b>		
	<b>Basic planning parameters</b>		
FSR 4.320	General information	FSR 4.300	Wall through-connections Type MD
FSR 4.321	Planning the routing	FSR 4.301	Wall breakthroughs, core holes
FSR 4.322	Determining the pipe lengths involved	FSR 4.302	Steel manhole and pipe sleeve openings
FSR 4.323	Details for excavation work	FSR 4.303	Annular space seal for core hole or fibre cement casing
	<b>Fluid engineering</b>	FSR 4.304	Fire prevention through-connection, bulkheading
FSR 4.330	Pressure loss diagramme for Regular and Super (4 star) Petrol	FSR 4.307	Anchor fittings to buildings, pipe bridges etc.
FSR 4.331	Pressure loss diagramme for Heating oil (EL) and Diesel fuel		
FSR 4.332	Pressure loss diagramme for liquid propane		
FSR 4.333	Pressure loss diagramme for gaseous propane		
			<b>Texts for invitations to tender</b>
			Wordings of invitations to tender for FLEXWELL® Safety Pipe are available on request.

Pipe systems for tank facilities and service stations

By E-Mail to: info.brg@brugg.com

# Processing enquiries

By fax to: +49 5031 170-189

### Customer/Contractual partner:

Company: \_\_\_\_\_  
 Country: \_\_\_\_\_  
 Contact person: \_\_\_\_\_  
 eMail address: \_\_\_\_\_  
 Desired  
 date of offer: \_\_\_\_\_

### Project details:

Project designation: \_\_\_\_\_  
 Postcode / Town: \_\_\_\_\_  
 estimated project value (PW): \_\_\_\_\_ T€  
 Chance of getting order (AC): \_\_\_\_\_ %  
 Desired probable exec. date: \_\_\_\_\_  
 Competitors: \_\_\_\_\_

### Product group:

### Market segment:

FLEXWELL® Safety Pipe  \_\_\_\_\_  
 BRUGG-STAMANT®  \_\_\_\_\_  
 SECON®-X  \_\_\_\_\_  
 FLEXWELL®-LPG  \_\_\_\_\_  
 NIROFLEX®  \_\_\_\_\_  
 SPIRAFLEX®  \_\_\_\_\_  
 Training seminars  \_\_\_\_\_  
 Other  \_\_\_\_\_

Length: \_\_\_\_\_ m  
 Dimensions: DN \_\_\_\_\_  
 Layout:  for SECON®-X petrol station required  
 Routing:  for BRUGG-STAMANT® absolutely necessary  
 Principle sketch:  in other cases  
 Description of work to be done:  
 German  English

### Information on medium for FLEXWELL-Sicherheitsrohr®, BRUGG-STAMANT®-Sicherheitsrohr, SECON®-X or FLEXWELL®-LPG:

Substance to be carried: \_\_\_\_\_ Fire prevention:  Wall/ceiling thickness:  \_\_\_\_\_

Data for supply: Supply rate \_\_\_\_\_ Supply pressure \_\_\_\_\_ Temperature \_\_\_\_\_  
 \_\_\_\_\_ m³/h \_\_\_\_\_ bar \_\_\_\_\_ °C

Data for laying: In the ground  Empty pipe  Canal   
 Building  Pipe bridge  Other

Description of project: \_\_\_\_\_  
 \_\_\_\_\_  
 \_\_\_\_\_  
 \_\_\_\_\_

Date/Signature: \_\_\_\_\_  
 \_\_\_\_\_  
 \_\_\_\_\_

Customer BRUGG: \_\_\_\_\_  
 Project BRUGG: \_\_\_\_\_  
 \_\_\_\_\_  \_\_\_\_\_   
 \_\_\_\_\_  \_\_\_\_\_   
 \_\_\_\_\_  \_\_\_\_\_   
 \_\_\_\_\_  \_\_\_\_\_

Received by BRUGG: \_\_\_\_\_  
 \_\_\_\_\_   
 \_\_\_\_\_   
 Date/Signature: \_\_\_\_\_  
 \_\_\_\_\_

To be filled out by BRUGG Rohrsysteme

## Notes

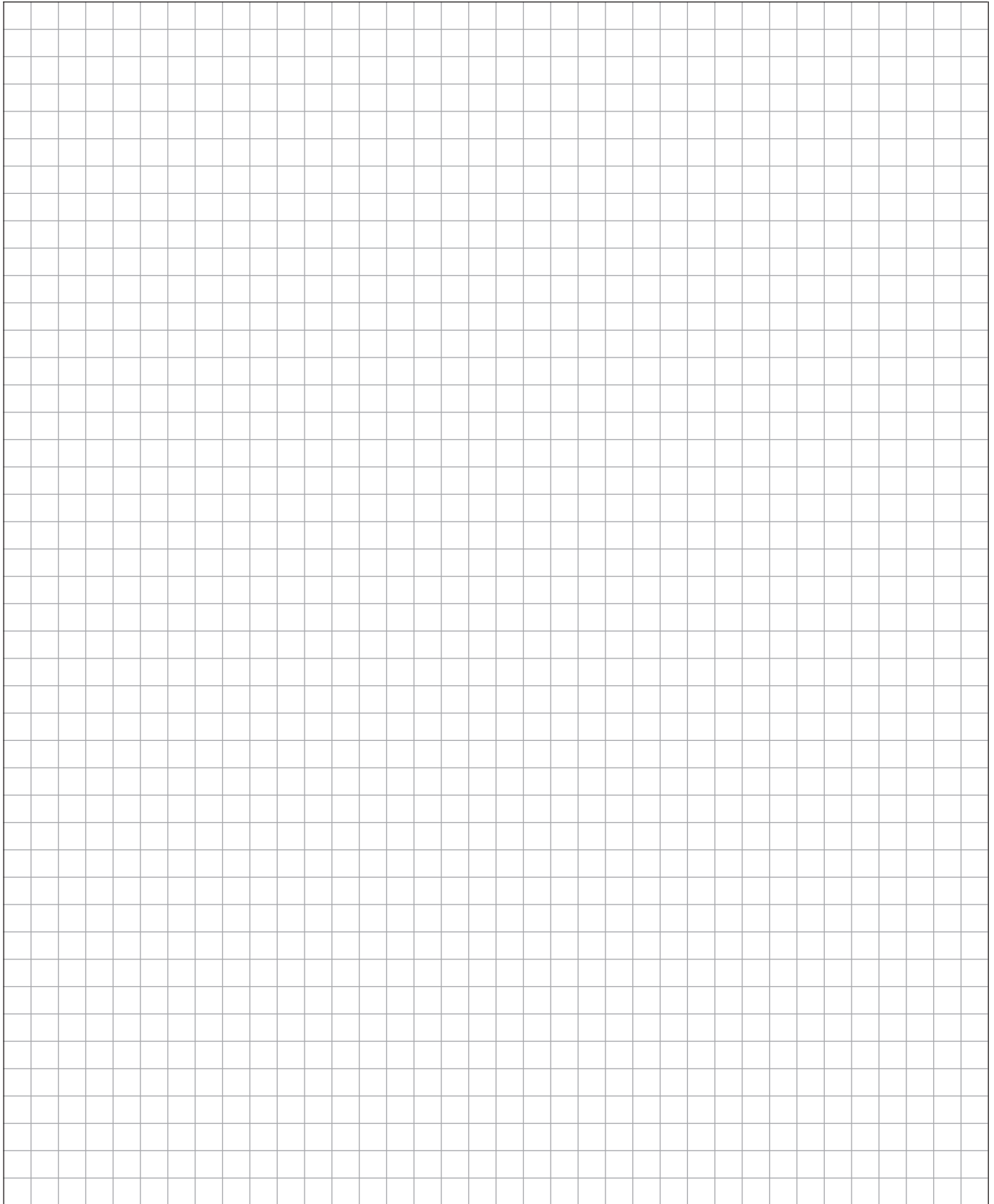

FLEXWELL® Safety Pipe

# Minutes of the hearing to award the contract/order

### Client (AG)

Company: \_\_\_\_\_

Street/Postbox:: \_\_\_\_\_

Postcode Town: \_\_\_\_\_

Telephone: \_\_\_\_\_

E-Mail: \_\_\_\_\_

Person spoken to/ \_\_\_\_\_

Function: \_\_\_\_\_

### Contractor (AN)

BRUGG Rohrsysteme GmbH

Adolf-Oesterheld-Straße 31

31515 Wunstorf

Person spoken to/Function: \_\_\_\_\_

\_\_\_\_\_

\_\_\_\_\_

### Project

\_\_\_\_\_

Address of construction site: \_\_\_\_\_

### The following was agreed upon

1. The following documents/agreements shall apply \_\_\_\_\_  
 and Conditions/Basis for discussions: \_\_\_\_\_  
 Offer(s), No./Date \_\_\_\_\_  
 Products \_\_\_\_\_  
 Technical remarks in advance/approvals \_\_\_\_\_  
 Existing "confirmed" drawings \_\_\_\_\_  
 Supplementary agreements: \_\_\_\_\_  
 \_\_\_\_\_  
 \_\_\_\_\_
  
2. Scope of work: \_\_\_\_\_  
 Offer No./Date \_\_\_\_\_  
 Contract specifications pages, items \_\_\_\_\_  
 Delivery, laying \_\_\_\_\_  
 Insulation after installation \_\_\_\_\_
  
3. Additional work to be done: \_\_\_\_\_  
 Addendum, if known \_\_\_\_\_  
 Services to be performed \_\_\_\_\_  
 (details of pricing/remuneration) \_\_\_\_\_

### Client

Date/Initials \_\_\_\_\_

### Contractor

Date/Initials \_\_\_\_\_



FLEXWELL® Safety Pipe

# Minutes of the hearing to award the contract/order

4. Drawings and other technical documents \_\_\_\_\_  
 (e.g. offer, contract specifications, \_\_\_\_\_  
 construction schedule, handover date): \_\_\_\_\_  
 Routing to be fixed by (person): \_\_\_\_\_  
 Routing plans to be provided by (person)/by (date): \_\_\_\_\_  
 To be checked /confirmed by (person)/by (date): \_\_\_\_\_

5. Certificates and other documentation: \_\_\_\_\_  
 \_\_\_\_\_  
 \_\_\_\_\_

6. Dates: \_\_\_\_\_  
 Drawings and other \_\_\_\_\_  
 Technical documentation \_\_\_\_\_  
 Deliveries \_\_\_\_\_  
 Start of installation work \_\_\_\_\_  
 Completion of installation work \_\_\_\_\_  
 Interim deadlines \_\_\_\_\_

7. Time overruns: \_\_\_\_\_

8. Price(s): as per offer(s) No./Date \_\_\_\_\_  
 Contract specifications pages, items \_\_\_\_\_  
 Valid until \_\_\_\_\_  
 \_\_\_\_\_

9. Payment terms: \_\_\_\_\_  
 Net of deductions, trade discount \_\_\_\_\_  
 Payment terms \_\_\_\_\_  
 Payments on account for deliveries of material \_\_\_\_\_  
 Payments on account for installation work \_\_\_\_\_

**Client**  
 Date/Initials \_\_\_\_\_

**Contractor**  
 Date/Initials \_\_\_\_\_

FLEXWELL® Safety Pipe

# Minutes of the hearing to award the contract/order

10. Security for payment: \_\_\_\_\_  
 advance payment, bond/guarantee etc. \_\_\_\_\_  
 \_\_\_\_\_

11. Proof of performance/Basis for settlement: \_\_\_\_\_  
 Bill of quantities, fixed price, \_\_\_\_\_  
 delivery receipt, drawing \_\_\_\_\_

12. Warranties: \_\_\_\_\_  
 as per offer, any agreements which \_\_\_\_\_  
 deviate from that \_\_\_\_\_

13. Interruption, cancellation: \_\_\_\_\_  
 \_\_\_\_\_

14. Other: \_\_\_\_\_  
 \_\_\_\_\_  
 \_\_\_\_\_  
 \_\_\_\_\_  
 \_\_\_\_\_

The order is hereby granted.\*  
 The order is granted on the basis of the conditions agreed herein, and without delay after the client received an order in his turn.\*

\* Please delete whichever not applicable!

Place/Date \_\_\_\_\_

**Client**  
 Company stamp/Signature

**BRUGG Rohrsysteme GmbH**  
**Contractor**  
 Signature

\_\_\_\_\_

### FLEXWELL® Safety Pipe

Pipe system for installations

**Flexible, double-walled pipe system with stainless steel inner pipe and outer containment pipe and permanent leak detection with approval Z-38.4-253**

#### SYSTEM DESCRIPTION

FLEXWELL® Safety Pipe was specially designed for the underground transport of flammable, water-hazardous fluids. It can be used as a suction or positive pressure supply pipe. The FLEXWELL® Safety Pipe can be permanently monitored by means of suitable leak detectors.

#### CONSTRUCTION

FLEXWELL® Safety Pipe is a flexible, permanently monitorable, double-walled pipe system. The FLEXWELL® Safety Pipe consists of a corrugated stainless steel inner medium pipe, a reinforcing band and a corrugated outer containment pipe made of stainless steel. The annular gap between the inner and outer pipes is a surveillance space for leak monitoring. External corrosion protection is provided by a PE casing covering the outer pipe.

#### RANGE OF APPLICATIONS

- suction pipe
- positive pressure supply pipe
- filling pipe



#### NOMINAL BORES / PRESSURE STAGES

FLEXWELL® Safety Pipe is available in nominal bores from DN 12 to DN 150. It can be operated with positive pressure up to max. 25 bar.

#### LAYING THE PIPES

FLEXWELL® Safety Pipe can be laid directly into the trench in one piece. It can be laid either overground in a trace or inside of buildings. The unique corrugated pipe geometry of inner medium pipe and outer containment pipe ensures excellent flexibility. It can be cut to the required length at the construction site, laid "endlessly" and bent through tight radii thanks to its flexibility.

#### DOUBLE-WALLED FITTINGS

Monitorable through-connections and T-pieces as well as connectors with measuring branches are all part of the comprehensive range of products available in the FLEXWELL® Safety Pipe programme.

#### LEAK MONITORING

The surveillance space between the inner and outer pipes can be permanently monitored by means of suitable positive or negative pressure leak detectors. A wide range of leak detection systems for different areas of application and legal requirements is available.

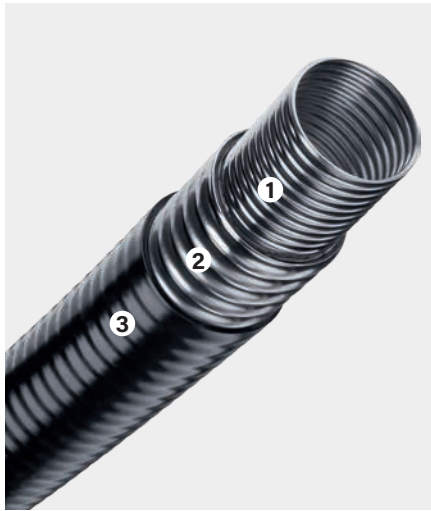

FLEXWELL® Safety Pipe

- 1 corrugated inner medium pipe of stainless steel
- 2 corrugated outer containment pipe of stainless steel
- 3 polyethylene casing

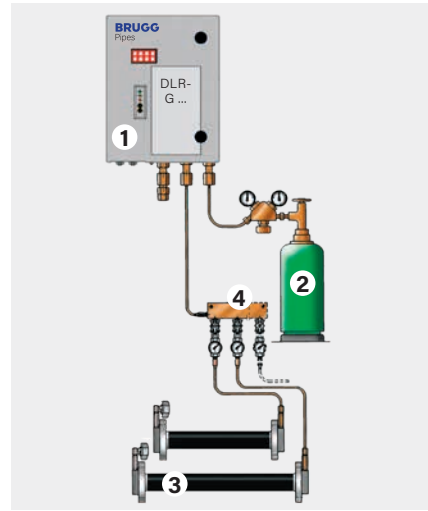

Positive pressure leak detector

- 1 leak detector
- 2 pressure reservoir
- 3 double-walled corrugated FLEXWELL® Safety Pipe with measuring branch and test valve
- 4 distributor

### Technical data FLEXWELL® Safety Pipe

Material:	inner pipe	1.4404/1.4571
	outer pipe	1.4301
	reinforcing band	steel
	corrosion proofing	PE-LD casing
Operating pressure inner pipe:	vacuum	suction pipe up to -0.8 bar
	positive pressure	up to 25 bar (depending on nominal bore)
Monitoring pressure outer pipe, permanent:	vacuum	-0.7 bar
	positive pressure	up to 25 bar (depending on operating pressure and nominal bore)

### Dimensions

Type	Nominal bore DN	Inner diameter mm	Outer diameter mm	Volume inner pipe l/m	Weight kg/m	Bending radius cm
FSR 13/ 25	12	13	25	0.13	0.52	30
FSR 30/ 48	25	30	48	0.80	1.40	50
FSR 39/ 60	32	39	60	1.30	2.00	60
FSR 48/ 71	40	48	71	2.00	2.90	60
FSR 60/ 83	50	60	83	3.00	3.80	70
FSR 75/107	65	75	107	5.10	6.20	90
FSR 98/134	80	98	134	8.40	9.00	120
FSR 127/175	100	127	175	14.00	18.10	150
FSR 200/262	150	200	262	23.20	29.00	400

FLEXWELL® Safety Pipe

# Notizen

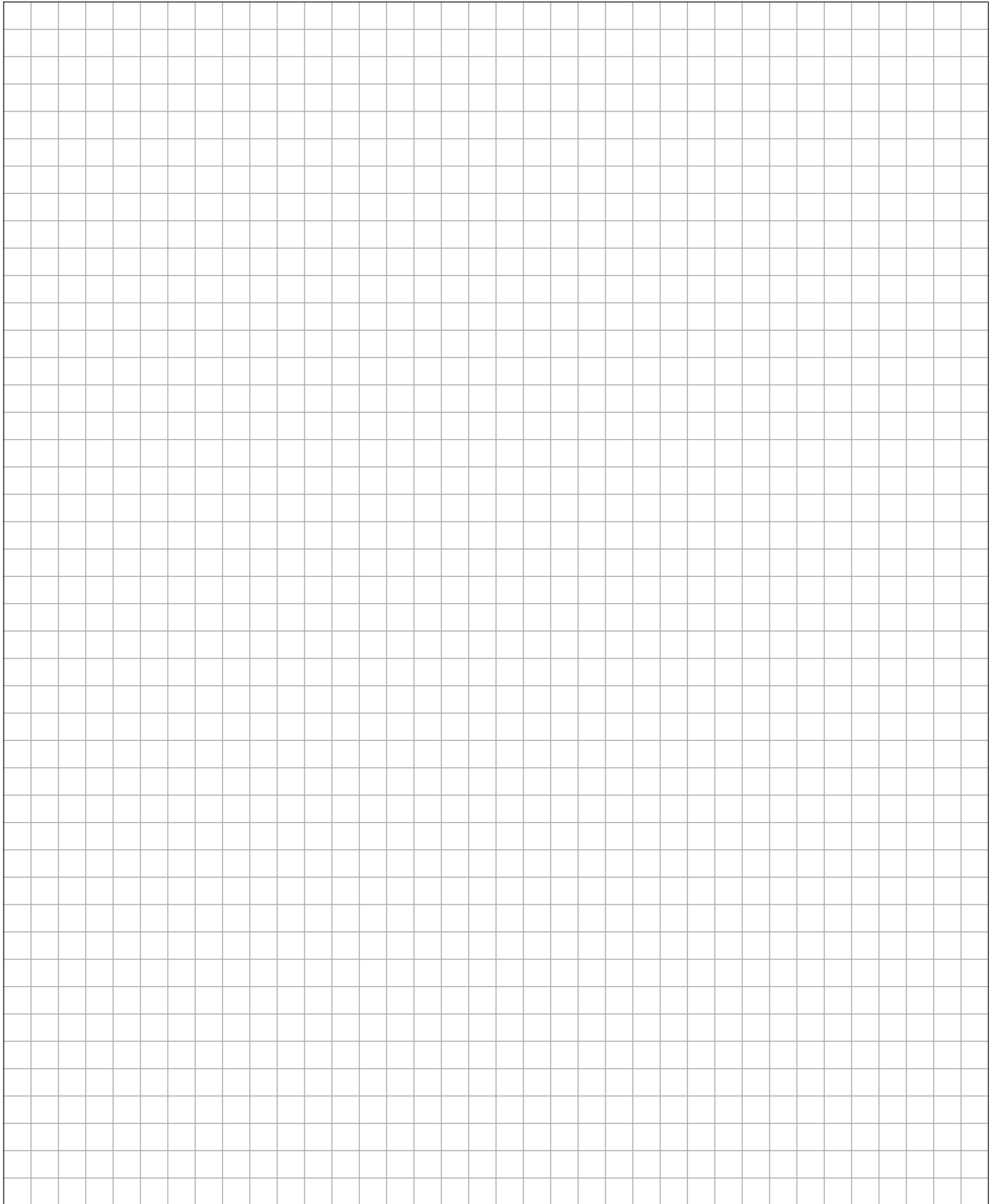

## FLEXWELL® Safety Pipe

**Resistance of material**

The resistances for Materials No. 1.4404 for the inner pipe and 1.4301 for the outer pipe against various fluids acc. to DIN 6601 are confirmed as regards the following selection of transport media:

Petrol DIN EN 228

Petroleum spirit DIN 51632 – 1

Petroleum spirit DIN 51632 – 2

Petroleum spirit DIN 51632 – 3

Petroleum spirit DIN 51632 – 4:

auto ignition temperature > 55 °C,

auto ignition temperature > 61 °C

Diesel fuels DIN EN 590

Diesel fuels: 61 < auto ignition temperature ≤ 100 °C

Diesel fuels: auto ignition temperature ≤ 61 °C

Biodiesel

AdBlue – carbamide, diluted

Kerosine: 21 ≤ auto ignition temperature ≤ 55 °C

Heating oil, light: 61 < auto ignition temperature ≤ 100 °C

Heating oil, light: auto ignition temperature as per EN 590

Heating oil DIN 51603

Hydraulic fluid DIN 51502 – HFC

Hydraulic fluid DIN 51502 – HFD-R

Hydraulic fluid DIN 51502 – HFC-T

Hydraulic oil DIN 51524

Hydraulic oil DIN 51524

Refrigerating machine oil DIN 51503

Motor oil SAE

Oils DIN 51502 – F

Oils DIN 51502 – J

Oils DIN 51502 – R

Lubricating oils DIN 51501

Lubricating oils DIN 51502

Lubricating oils DIN 51506

Lubricating oils DIN 51510

Lubricating oils DIN 51513

Lubricating oils DIN 51515

Lubricating oils DIN 51517

Methanol

Methanol, diluted

Ethanol

Ethanol in aqueous solution

Bioethanol

Isopropanol

Diethylene glycol/Glycol

Caustic soda solution up to max. 50 % NaOH

Ammoniac

Diluted ammoniac: 0,88 ≤ concentration ≤ 0,957  
at 15 °C in water, 10 up to 35 %

Toluene

**Certification of resistances for further fluids**

The resistance of the pipe material for the medium-carrying pipes must be certified acc. to DIN 6601 (Positive Fluid list) or as a qualified individual test certificate.

**Please note!**

The properties of particular transport media must be considered for each project.

## FLEXWELL® Safety Pipe

# Basic planning parameters

## General information

In contrast to conventional piping, FLEXWELL® Safety Pipe is a flexible pipe system. It is manufactured in our works in endless lengths and wound onto cable drums. Due to its flexibility FLEXWELL® Safety Pipe can be laid in one piece over long stretches of the routing without any need for moulded parts. Installation work to assemble and fit pipe connections and to insulate the piping on site is only necessary at the ends of the pipe sections.

### Delivery lengths

Type	DN	Delivery lengths	
		on a drum m	as a coil m
FSR 13/ 25	12	500	500
FSR 30/ 48	25	750	525
FSR 39/ 60	32	650	415
FSR 48/ 71	40	550	255
FSR 60/ 83	50	500	200
FSR 75/107	65	400	125
FSR 98/134	80	400	90
FSR 127/175	100	350	50
FSR 200/262	150	250	–

Longer pipe lengths are connected on site with monitorable through-connections.

### Expansion takeup

Longitudinal expansion as a result of thermal influences is compensated in FLEXWELL® Safety Pipe rather like an expansion joint by the geometrical change in the corrugation of the pipes. That is why no action needs to be taken to compensate for expansion when using FLEXWELL® Safety Pipes. Expansion bends such as those needed on conventional piping can be dispensed with.

### Anchor points

Anchor points are not necessary when the pipe is laid underground. In this case, the routing can be chosen completely freely and causes no extra work. Increase in the volume of fluids due to thermal influences and concomitant pressure increases can be compensated to a limited extent in surface laying.

### Safety precautions

The following technical principles apply to FLEXWELL® Safety Pipe, and correspond to best engineering practice:

- Piping must be equipped with all devices needed for safe operations.
- Piping must be secured against exceeding the permissible pressures where it is cannot be excluded that such pressures may be exceeded.
- The safety equipment to prevent exceeding of permissible pressure must be installed in an appropriate position.
- For instance, spill valves are a suitable means of preventing pressure increases exceeding the permissible level as a result of temperature increases in flammable fluids e.g. due to exposure to sunshine.
- Unenclosed piping must be tightly sealed against fluid loss.
- Surface routed piping which is directly exposed to the sun must be shielded from sunshine using appropriate means.

### Screws and seals

Screws and seals are not included in the scope of delivery.

**IMPORTANT!** Only use steel screws of strength class 4.6, 5.6 or 8.8. Screws of strength class  $\geq 10.9$  may not be used. When stainless steel screws are used, the area underneath the heads and on the thread must be lubricated with copper paste. This is absolutely necessary for the friction coefficient and maximum tightening torque. Only stainless steel screws with maximum strength class A 70 may be used.

### Installation instruction for split loose flange

The splitting of the loose flange needs to be installed staggered 90° in reverse order.

FLEXWELL® Safety Pipe

Basic planning parameters

Routing

Routing with branching off pipes

Where a number of differently located users need to be supplied by piping, this is normally done with conventional piping by laying feeder lines branching off from the main line. This makes it necessary to install T-branches, creating extra work on site. In the case of underground piping this also creates an extra risk, since the branches can neither be seen nor easily checked for leaks.

The flexibility of FLEXWELL® Safety Pipe allows it to be laid according to the "looping in" method familiar from high-voltage power cables (see the diagramme).

"Looping in" means:

- 1. The actual branching-off pipe, illustrated as a bridgeover, lies in an area where it is protected or easy to check (e.g. in a manhole pit or the boiler room.)
- 2. There is no connection to be installed by hand in the ground. This means that the corrosion-proofing fitted during manufacture in our factory is at no point interrupted in the underground routing.

Corrosion-proofed and completely monitorable T-branches can be delivered for special cases. We would like to point out however that "looping in" is normally much more economical than fitting monitorable T-branches.

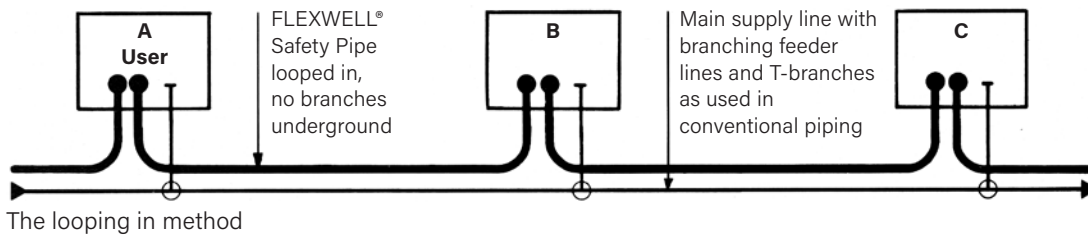

Pipe gradient, existing supply lines, stray currents

It makes a lot of sense to lay FLEXWELL® Safety Pipe with the gradients normally used in piping construction in order to be able to easily evacuate and vent the pipes or systems. In heavily built-up areas it is often the case, however, that already existing supply lines cross the planned routing. As long as no minimum distances between lines are stipulated by law or by the owners, FLEXWELL® Safety Pipe can simply be "threaded" through the crossing lines or led around other obstacles (see the diagramme). This only applies to positive pressure lines however. In the case of suction pipes, upward "jumps" greater than the internal diameter of the inner pipe are not permissible.

The rules of good engineering practice for pipelaying must be observed in all cases. In particular the properties of the transport media must be taken into consideration.

FLEXWELL® Safety Pipe is protected from stray currents due to its uninterrupted PE casing. This is proved by a 20 kV high voltage test in factory. In the vicinity of direct-current installations (tramlines, cathodically protected piping) it can be laid without there being any disadvantages to any part of the installation expected.

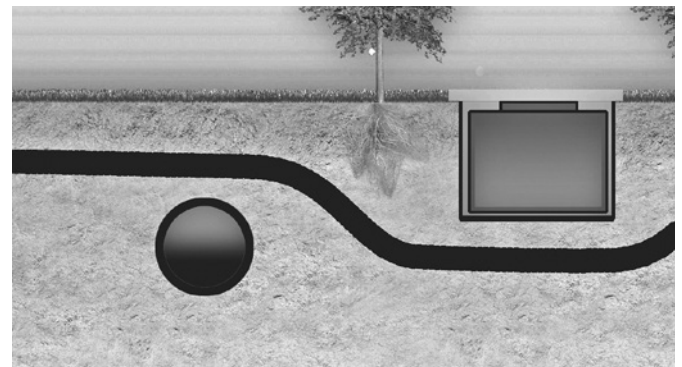

Routing around underground obstacles

FLEXWELL® Safety Pipe

## Basic planning parameters

Determining the lengths

Example of a routing sketch with determination of the lengths for FSR 39/60

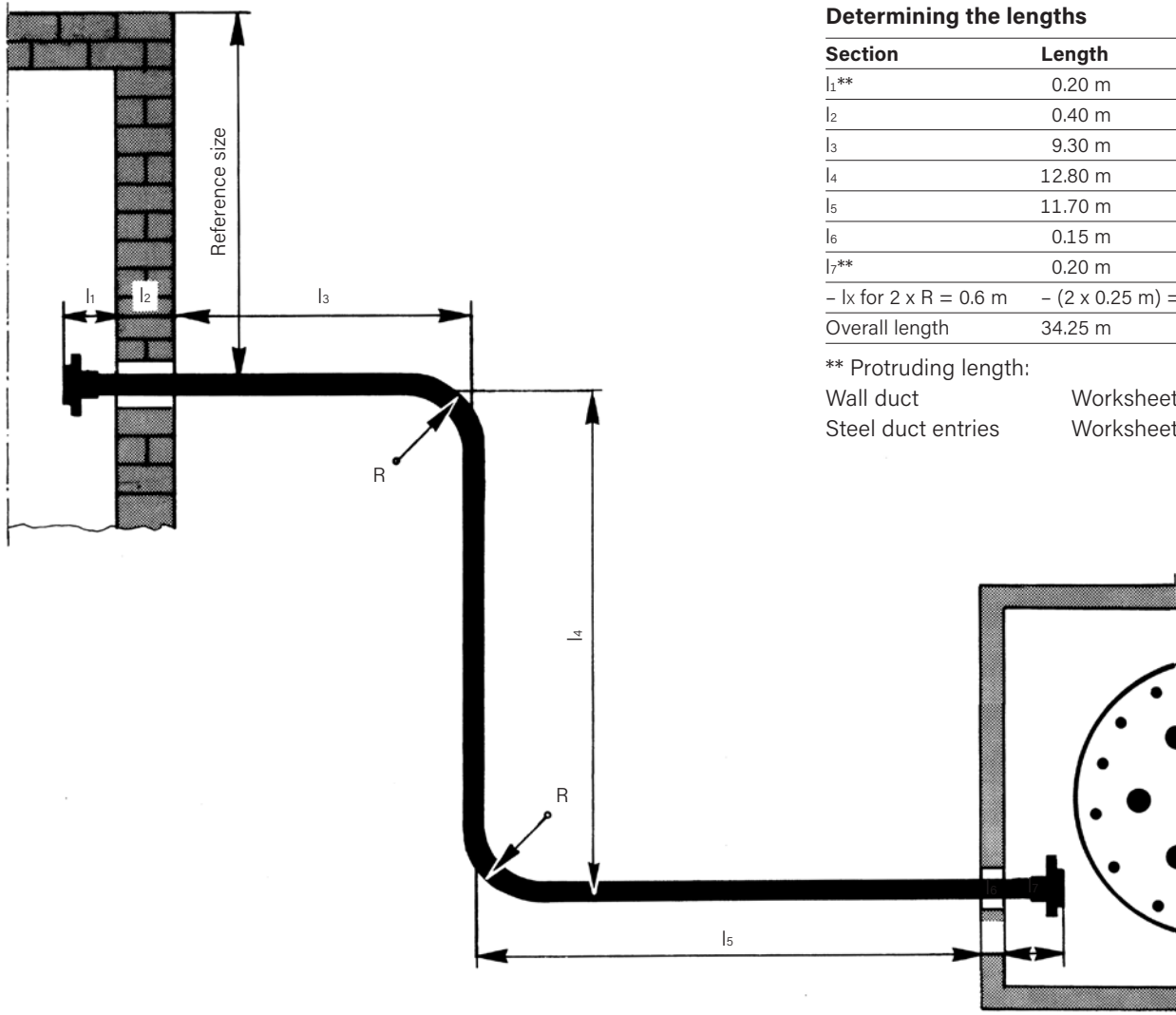

### Determining the lengths

Section	Length
$l_1^{**}$	0.20 m
$l_2$	0.40 m
$l_3$	9.30 m
$l_4$	12.80 m
$l_5$	11.70 m
$l_6$	0.15 m
$l_7^{**}$	0.20 m
- $l_x$ for $2 \times R = 0.6$ m	- $(2 \times 0.25$ m) = - 0.50 m
Overall length	34.25 m

\*\* Protruding length:

Wall duct                      Worksheet FSR 4.300

Steel duct entries            Worksheet FSR 4.302

Type	for a bending radius $R^*$ from	for a 90° elbow deduct from value $l_x$
FSR 13/ 25	0.3 m	$l_x = - 0.12$ m
FSR 30/ 48	0.5 m	$l_x = - 0.21$ m
FSR 39/ 60	0.6 m	$l_x = - 0.25$ m
FSR 48/ 71	0.6 m	$l_x = - 0.25$ m
FSR 60/ 83	0.7 m	$l_x = - 0.30$ m
FSR 75/107	0.9 m	$l_x = - 0.39$ m
FSR 98/134	1.2 m	$l_x = - 0.52$ m
FSR 127/175	1.5 m	$l_x = - 0.64$ m
FSR 200/262	4.0 m	$l_x = - 1.70$ m

\* Minimum bending radius  $R$  min. – generally done using a mechanical bending device.

FLEXWELL® Safety Pipe

# Basic planning parameters

Details for underground work

## Pipe trench

FLEXWELL® Safety Pipe should be laid on top of a sand bedding at least 10 cm deep (grit size ≤ 2 mm) and covered over according to the rules of TrbF 50 Point 5.4.3 (2) with the same sand. The standards and regulation given below must be observed.

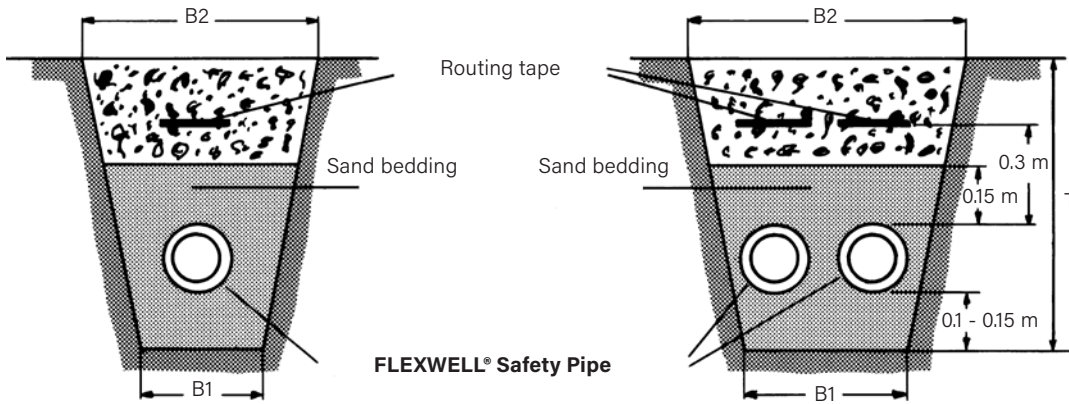

The routing tape is delivered by BRUGG and must be laid on site.

Type FSR	laying radii R* m	trench depth T m	trench width B1 m	trench width B2 m	spoil m³/lfd. m	Sand filling m³/lfd. m
13/ 25	0.7	0.95	0.30 (0.40)	0.67 (0.73)	0.46 (0.54)	0.09 (0.11)
30/ 48	0.7	0.95	0.30 (0.40)	0.67 (0.73)	0.46 (0.54)	0.09 (0.11)
39/ 60	1.0	1.00	0.30 (0.40)	0.70 (0.75)	0.50 (0.58)	0.10 (0.14)
48/ 71	1.2	1.00	0.30 (0.40)	0.70 (0.75)	0.50 (0.58)	0.10 (0.14)
60/ 83	1.5	1.00	0.30 (0.40)	0.70 (0.75)	0.50 (0.58)	0.10 (0.14)
75/107	1.8	1.05	0.30 (0.40)	0.70 (0.75)	0.53 (0.60)	0.11 (0.15)
98/134	2.0	1.05	0.30 (0.40)	0.70 (0.75)	0.53 (0.60)	0.12 (0.16)
127/175	3.0	1.10	0.40 (0.50)	0.80 (0.90)	0.66 (0.77)	0.17 (0.22)
200/262	4.0	1.20	0.70 (1.10)	1.10 (1.50)	1.08 (1.56)	0.44 (0.67)

\* When **pulling the pipe** into the trench, it is not permissible to go below these radii. **Minimum bending radius** see Work-sheet FSR 4.322.

## Technical regulations and DIN Standards

When carrying out underground work for FLEXWELL® Safety Pipe the following DIN standards, regulations, provisions and guidelines must be observed:

- DIN 1072 Straßen- und Wegbrücken, Lastannahmen
- DIN 4124 Baugruben und -gräben; Böschungen, Verbau, Arbeitsraumbreiten
- DIN 18300 VOB, Teil C, Allgemeine technische Vorschriften; Erdarbeiten
- DIN 18303 VOB, Teil C, Allgemeine technische Vorschriften; Verbauarbeiten
- DIN 18307 VOB, Teil C, Allgemeine technische Vorschriften; Druckrohrleitungsarbeiten außerhalb von Gebäuden
- DIN 18320 VOB, Teil C, Allgemeine technische Vorschriften; Landschaftsbauarbeiten
- DIN 18330 VOB, Teil C, Allgemeine technische Vorschriften; Mauerarbeiten
- DIN 18195 Bauwerksabdichtungen
- DIN 18354 VOB, Teil C, Allgemeine technische Vorschriften; Asphaltbelagarbeiten
- DIN EN 1610 Entwässerungskanäle und Leitungen, Richtlinie für die Ausführung

Merkheft „Sicherung von Leitungsgräben und Baugruben“, Berufsgenossenschaft der Bauwirtschaft  
 Merkblatt über das Zufüllen von Leitungsgräben, Forschungsgesellschaft für das Straßenwesen e.V., Arbeitsgruppe Untergrund  
 Accident pevention regulations and general regulations of the Employers’ Liability Insurance associations (Berufsgenossenschaften)

The gradients normally used in pipeline constructions must be observed when digging the pipe trench.



FLEXWELL® Safety Pipe

# Fluid engineering

Pressure loss diagramme for petrol regular and super (4 star)

Temperature: 15 °C  
 Specific weight: 735 kg/m<sup>3</sup>  
 Kinematic viscosity: 5.5 · 10<sup>-7</sup> m<sup>2</sup>/s

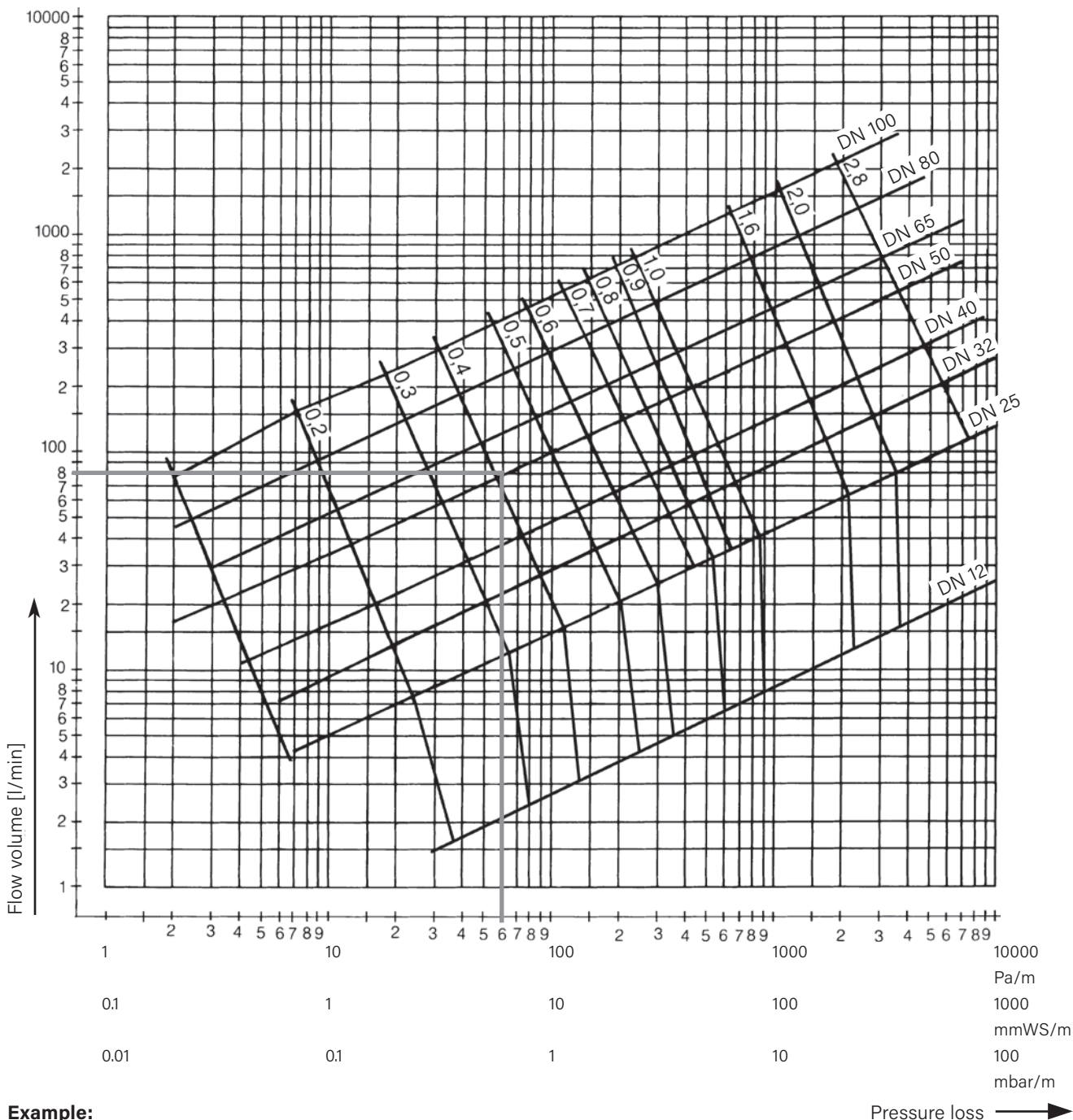

**Example:**

Pipe DN 50  
 With a flow volume of 80 l/min  
 at a speed of c. 0.4 m/s  
 the pressure loss is 0.6 mbar/m

Pressure loss →

FLEXWELL® Safety Pipe

# Fluid engineering

Pressure loss diagramme for heating oil (EL) and diesel fuel

Temperature: 15 °C  
 Specific weight: 860 kg/m³  
 Kinematic viscosity: 7 · 10<sup>-6</sup> m²/s

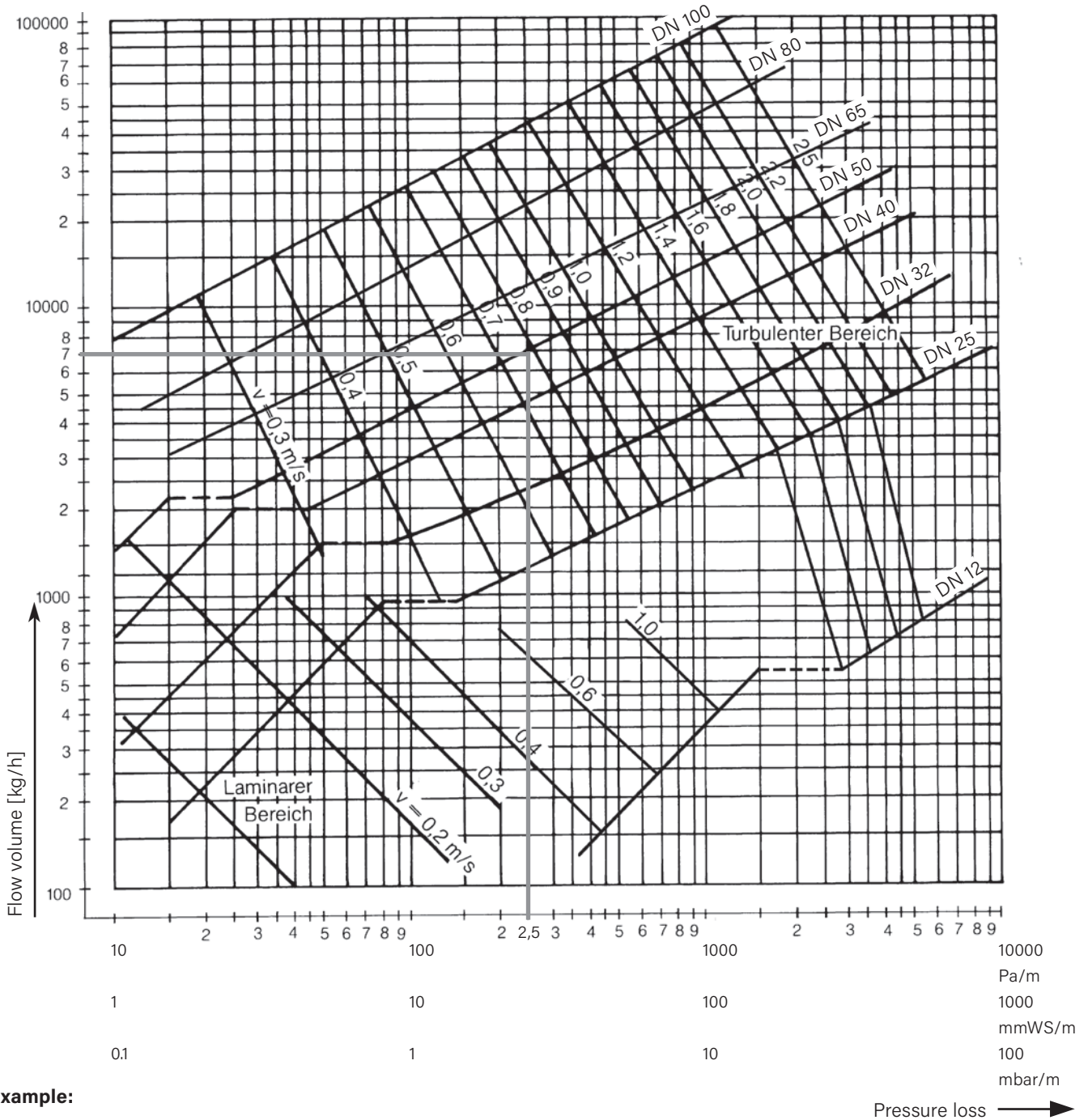

**Example:**

Pipe DN 50  
 With a flow volume of 7000 kg/h  
 at a speed of c. 0.8 m/s  
 the pressure loss is 2.5 mbar/m

Pressure loss →

FLEXWELL® Safety Pipe

# Fluid engineering

## Pressure loss diagramme for liquid propane

Temperature: 15 °C  
 Specific weight: 508 kg/m<sup>3</sup>  
 Kinematic viscosity: 2.1 · 10<sup>-7</sup> m<sup>2</sup>/s

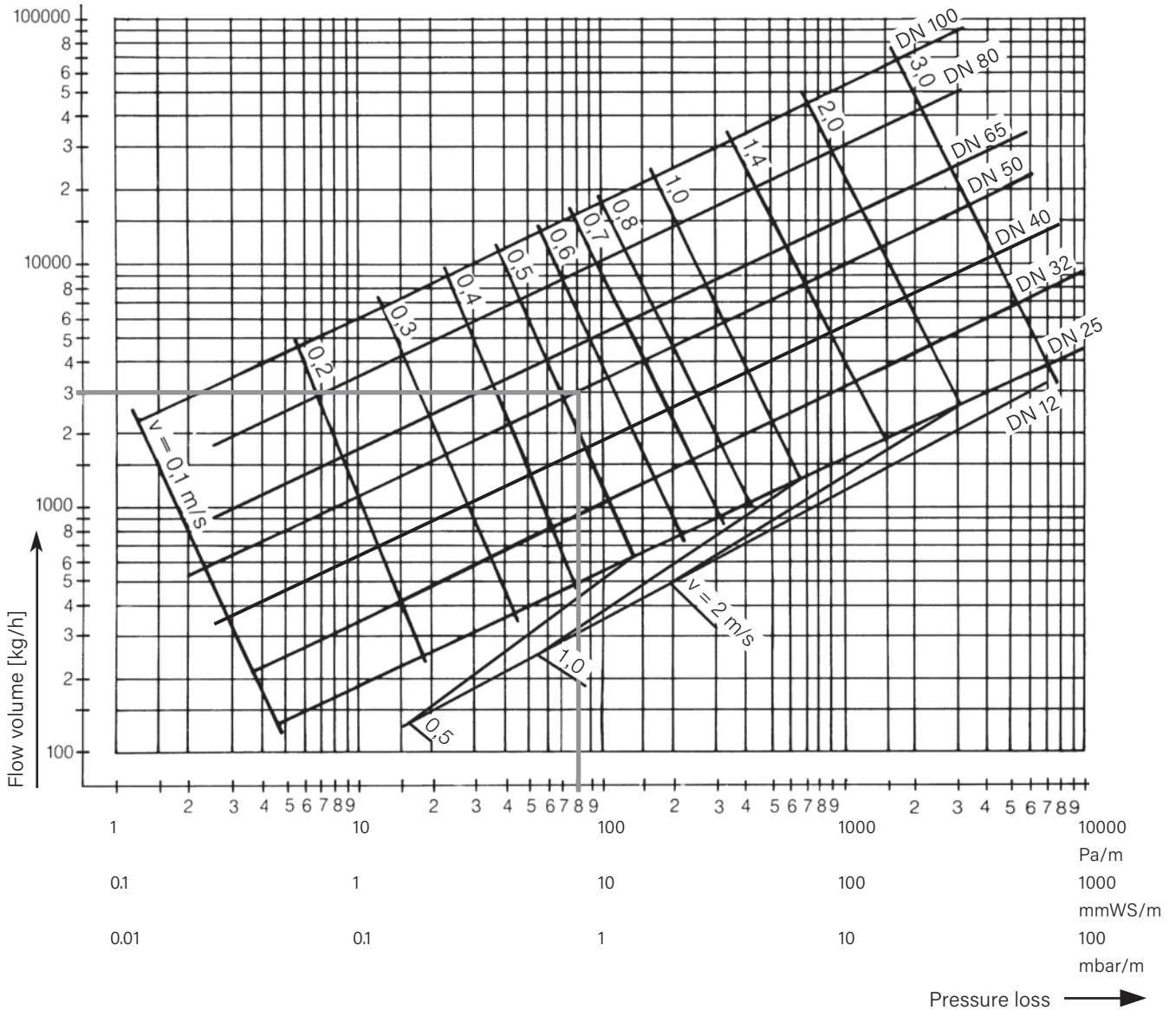

**Example:**

Pipe DN 50  
 With a flow volume of 3000 kg/h  
 at a speed of c. 0.5 m/s  
 the pressure loss is 0.8 mbar/m

FLEXWELL® Safety Pipe

**Fluid engineering**

Pressure loss diagramme for gaseous propane

Temperature: 15 °C  
 Specific weight: 8 kg/m<sup>3</sup> (3 bar)  
 Dynamic viscosity: 7.9 · 10<sup>-6</sup> Ns/m<sup>2</sup> = kg/ms

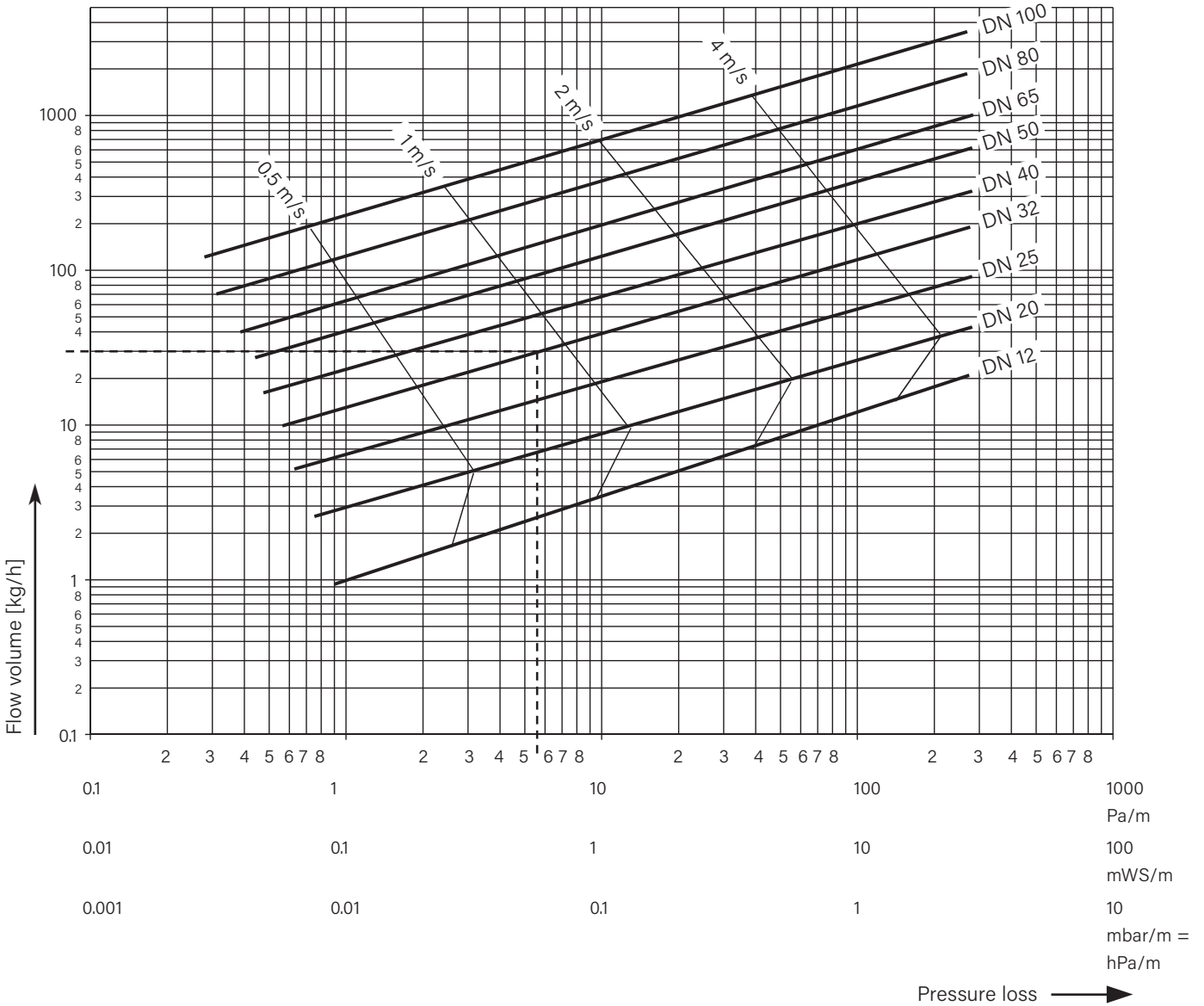

**Example:**

Pipe DN 32  
 With a flow volume of 30 kg/h  
 at a speed of c. 0.9 m/s  
 the pressure loss is 5.6 · 10<sup>-2</sup> mbar/m = 5.6 · 10<sup>-2</sup> hPa/m

FLEXWELL® Safety Pipe

# Wall duct Type MD

## General information

FLEXWELL® Safety Pipe wall duct Type MD must be cemented in on site. If the intallation is correctly executed, the tightness between the concrete and the through-connection and between the through-connection and the FLEXWELL® Safety Pipe is 0.2 bar.

### Wall duct Type MD for FSR 13/25 – FSR 60/83

The seal consists of a cross-linked polyolefin shrink sleeve, supported from within by a galvanized steel helix. When the two ends of this are heated using a gas flame they shrink, causing the sealing compound to melt and pressing it into any grooves or unevennesses of the surface.

Type MD	L mm	A mm	B max* mm	KD mm	D1 mm	Article No.
MD-FSR 13/25	200	800	450	100	21	1015749
MD-FSR 30/48	200	700	450	100	67	1015750
MD-FSR 39/60	200	750	450	150	116	1015751
MD-FSR 48/71	200	750	450	150	116	1015751
MD-FSR 60/83	200	750	450	150	116	1015751

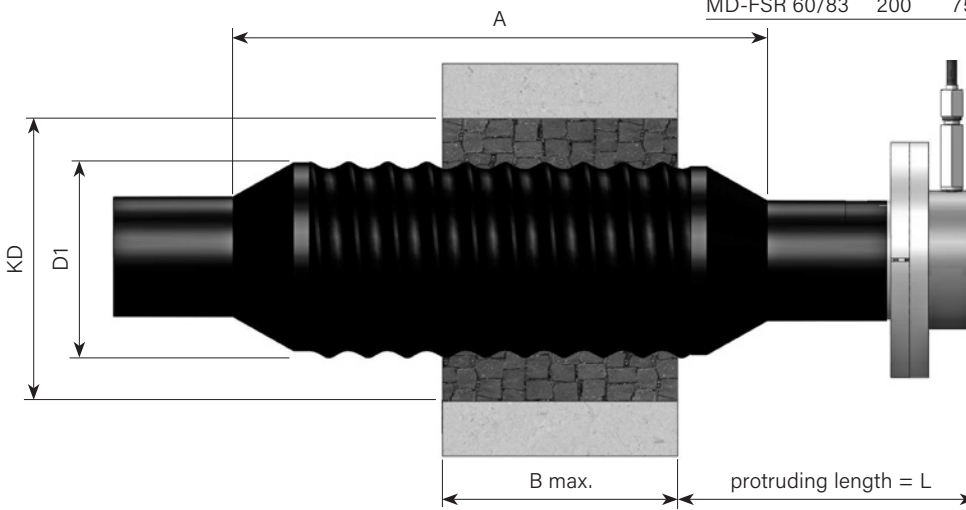

\* If walls are thicker, two wall ducts can be pushed inside one another.

### Dimension KD:

Observe the steps for preparation of the installation!

### Please note!

Push the wall duct over the pipe before installing the connection.

### Wall duct Type MD for FSR 75/107 – FSR 127/175

The sealing element consists of a sealing bush made of GG, a sealing fitting and a fixing ring. The sealing bush is fitted with radial spokes. These ensure the longitudinal watertightness of the seal rather like a labyrinth seal in concrete or mortar. The seal around the FLEXWELL® Safety Pipe consists of a sealing ring which is pressed into the sealing bush by means of an anchor fitting ring.

Type MD	L mm	A mm	KD mm	D1 mm	Article No.
MD-FSR 75/107	200	45	300	186	1015752
MD-FSR 98/134	250	45	300	200	1016067
MD-FSR 127/175	250	45	350	243	1015754

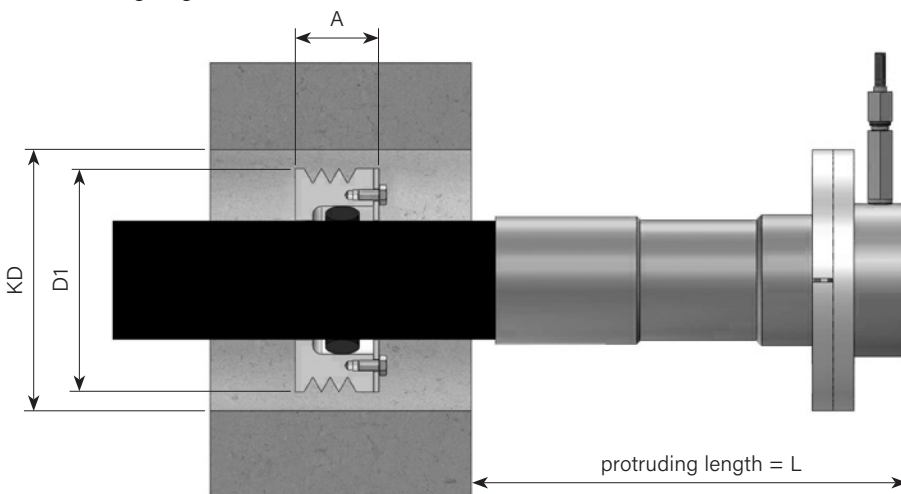

### Please note!

Push the wall duct over the pipe before installing the connection.

FLEXWELL® Safety Pipe

# Wall breakthroughs, core holes

## Wall breakthroughs for connections

Type	D Threaded socket mm	D Flange mm	H mm	B 1 Pipe mm	B 2 Pipes mm
FSR 13/ 25	40	-	100	100	200
FSR 30/ 48	-	115	215	215	400
FSR 39/ 60	-	140	240	240	400
FSR 48/ 71	-	150	250	250	400
FSR 60/ 83	-	165	265	265	450
FSR 75/107	-	185	300	300	500
FSR 98/134	-	200	400	400	700
FSR 127/175	-	270	400	400	700
FSR 200/262	300	-	400	400	800

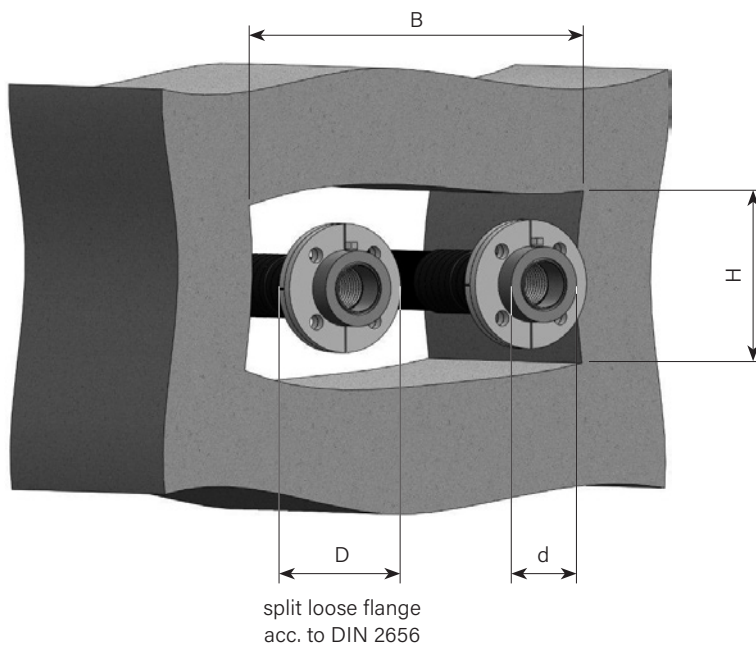

## Core holes for connections

Type	D mm	d mm	KD mm
FSR 13/ 25	-	40	80
FSR 30/ 48	115	68	100
FSR 39/ 60	140	78	125
FSR 48/ 71	150	88	125
FSR 60/ 83	165	102	150
FSR 75/107	185	122	200
FSR 98/134	200	138	200
FSR 127/175	270	190	250
FSR 200/262	-	300	400

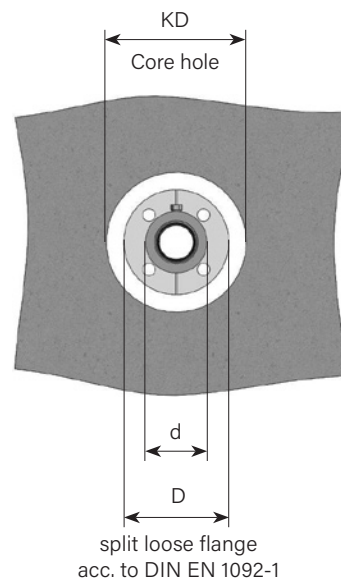

## FLEXWELL® Safety Pipe

**Steel duct and pipe sleeve entry****General information**

FLEXWELL® Safety Pipe steel duct entries Type SSE are designed to be used with fixed-size pipe sleeves. The pipe sleeves must be provided by the builders on site.

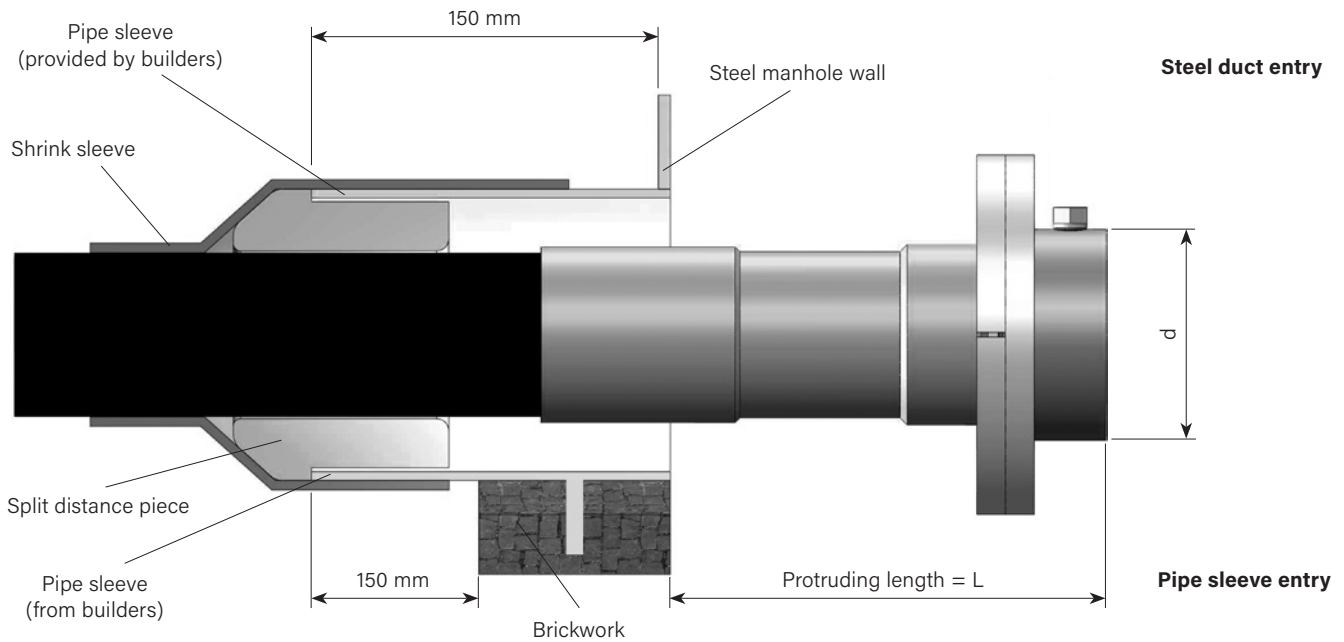

Type SSE	Pipe sleeve* (provided by builders)		Protruding length L mm	Article No.
	d1 x s1 mm	d mm		
SSE-FSR 13/ 25	48.3 x 2.6	40	150	1015551
SSE-FSR 30/ 48	76.1 x 2.9	68	200	1015553
SSE-FSR 39/ 60	88.9 x 3.2	78	200	1015554
SSE-FSR 48/ 71	114.3 x 3.6	88	200	1015552
SSE-FSR 60/ 83	114.3 x 3.6	102	200	1015555
SSE-FSR 75/107	168.3 x 4.5	122	200	1055682
SSE-FSR 98/134	168.3 x 4.5	138	250	1016048
SSE-FSR 127/175	219.1 x 5.9	190	250	1015557
SSE-FSR 200/262	323.9 x 8.8	300	400	auf Anfrage

\* For connecting fittings with monitorable sealing surface a separately request is needed.

## FLEXWELL® Safety Pipe

**Annular space seal**

for core hole or fibre cement casing

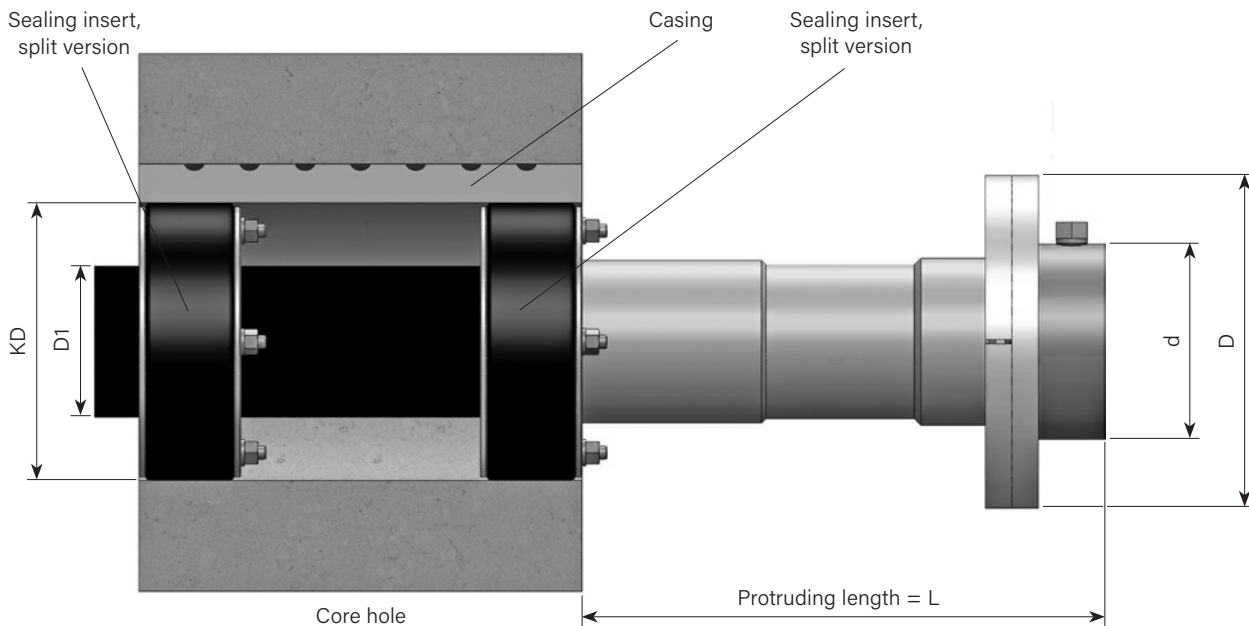
**Please note!**

Two annular ring seals are used to seal the annular space between the casing or core bore and the pipeline and to ensure the axial guidance of the piping. As the ring seals are in a split version they can also be installed after the installation of the pipeline. After installation of the seal insert the pipe must not be axially displaced or misaligned.

Type	DN	d mm	D mm	L mm	D1 mm	KD* mm	Article No.
RRD-FSR 13/ 25	12	40	-	150	25	80	1091460
RRD-FSR 30/ 48	25	68	115	200	48	100	1091462
RRD-FSR 39/ 60	32	78	140	200	60	125	1091469
RRD-FSR 48/ 71	40	88	150	200	71	125	1091470
RRD-FSR 60/ 83	50	102	165	200	83	150	1091471
RRD-FSR 75/107	65	122	185	200	107	200	1091476
RRD-FSR 98/134	80	138	200	250	134	200	1091475
RRD-FSR 127/175	100	190	270	250	175	250	1091478
RRD-FSR 200/262	150	300	-	400	262	350	on request

\* KD = Internal diameter of casing or diameter of core hole

Contents of the packaging unit = 2 pieces ring seal, split version

FLEXWELL® Safety Pipe

# Fire protection wall duct

Bulkheading for core hole or fibre cement casing or with fire protection insulation sleeve

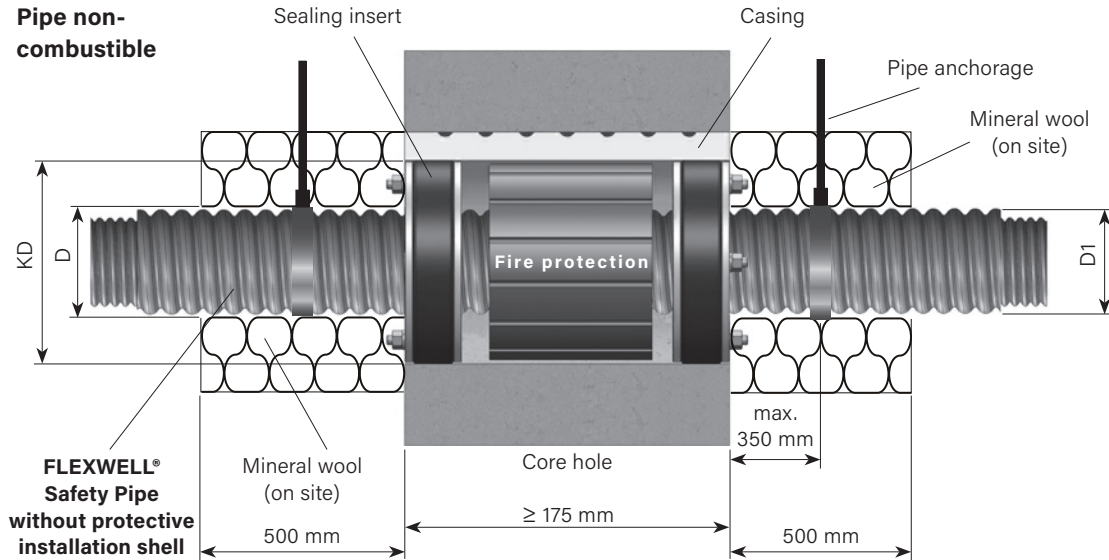

**To be made available by the builders**

Guidance values for both sides wrapped round with mineral wool:  
 Thickness: 80 mm  
 Density: 80 kg/m<sup>3</sup>  
 Length: ≥ 500 mm by R90

**Pipe anchorage**

The pipe have got to be insert horizontally into the wall.

**Parts for mounting**

Gas- and watertight pipe bulkheading with fire protection packing and sound-proofing according to DIN 4109  
 Metal parts: zinc-plated steel  
 Seal: EPDM  
 Casing: Special fibre cement optional

Type	DN	D mm	D1 mm	KD* mm	Article No.**
BSD-FSR 13/25	12	21.9	25.0	80	1016049
BSD-FSR 30/48	25	43.0	48.0	100	1016051
BSD-FSR 39/60	32	53.5	60.0	125	1016053
BSD-FSR 48/71	40	64.5	71.0	125	1016055
BSD-FSR 60/83	50	76.5	83.0	150	1016057

\* KD = Internal diameter of the casing or diameter of the core hole  
 \*\* not from stock/bigger dimensions on demand

**Fire protection packing R90**

Wall thickness > 400 mm = two fire protection packings are needed

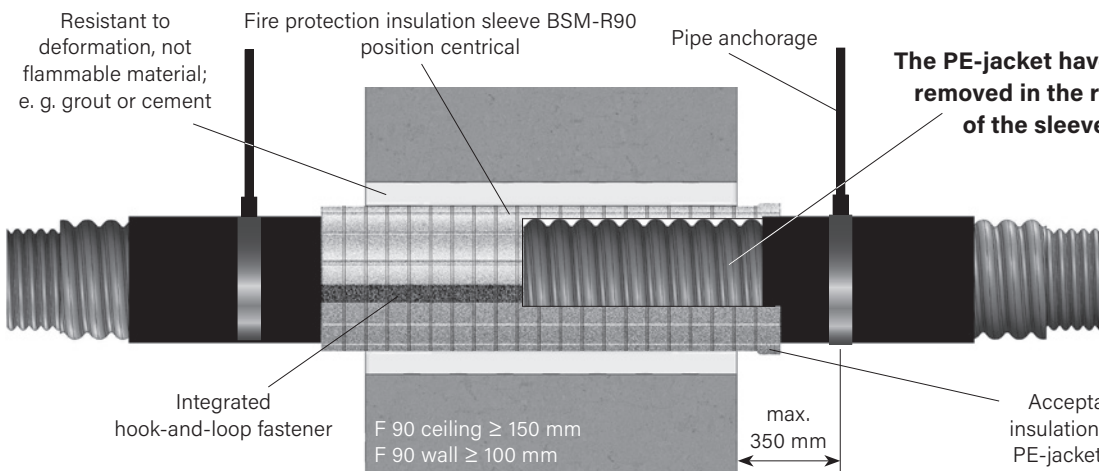

**Pipe anchorage**

The pipe have got to be insert horizontally into the wall.

Type	Length in mm	Article No.
BSM-FSR 13/25	350	1060635
BSM-FSR 30/48	350	1060637
BSM-FSR 39/60	500	1060639
BSM-FSR 48/71	500	1060640
BSM-FSR 60/83	500	1060641
BSM-FSR 75/107, 98/134	700	on request

## FLEXWELL® Safety Pipe

**Anchor fittings to buildings, pipe bridges etc.****Anchor fitting in buildings or on supporting structures****Installation example No. 1****BRUGG anchor fitting**

Anchor fitting of the FLEXWELL® Safety Pipe on existing installation rails mounted on plaster by means of bracket clamps.

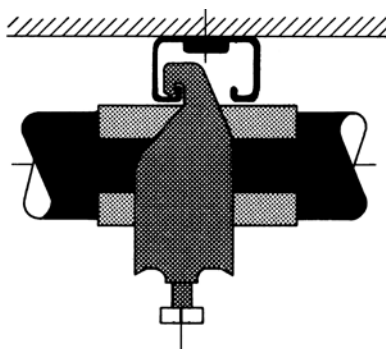
**Installation example No. 2**

Anchor fitting of the FLEXWELL® Safety Pipe on existing structural steel anchor rails embedded in the concrete (Jordahl or other anchor rails) by means of bracket clamps.

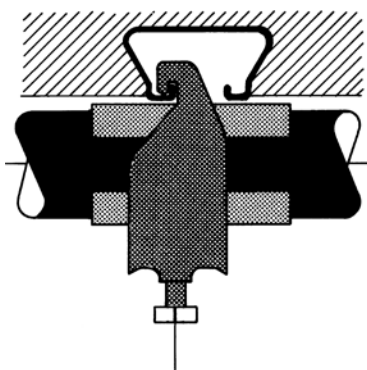
**N.B.:**

Apart from the components illustrated here, other bracket clamps normally in use in the trade with appropriate dimensions may be used with the anchor fitting.

Always take the local circumstances into consideration.

Fixing the anchor fitting to anchor rails or structural steel does however have the following advantages over fitting to an anchor point:

1. The FLEXWELL® Safety Pipe can be provisionally secured during laying.
2. To align the pipe correctly, the anchor fitting brackets only need to be loosened, pushed a little to one side and then tightened again afterwards.

**Bending radii and bracket distances**

Type	Bending radius	Bracket distance max.		Article No. BRUGG cable saddles galvanized steel	Brackets provided by builders must be suitable for use with following pipe-Ø
		horizontal	vertical		
	m	m	m		mm
KSS-FSR 13/ 25	0.30	1.00	1.20	1015541	25 – 30
KSS-FSR 30/ 48	0.50	1.20	1.40	1015544	48 – 52
KSS-FSR 39/ 60	0.60	1.40	1.60	1015545	60 – 65
KSS-FSR 48/ 71	0.60	1.50	1.70	1015543	70 – 75
KSS-FSR 60/ 83	0.70	1.60	1.80	1015546	83 – 90
KSS-FSR 75/107	0.90	1.60	1.90	1015547	107 – 112
KSS-FSR 98/134	1.20	1.60	2.00	1015549	134 – 140
KSS-FSR 127/175	1.50	1.60	2.00	1015550	170 – 180
KSS-FSR 200/262	4.0	1.80	2.00	on request	260 – 280
Anchor rail 250 mm				1015540	
Anchor rail 500 mm				1015539	

FLEXWELL® Safety Pipe

## Notes

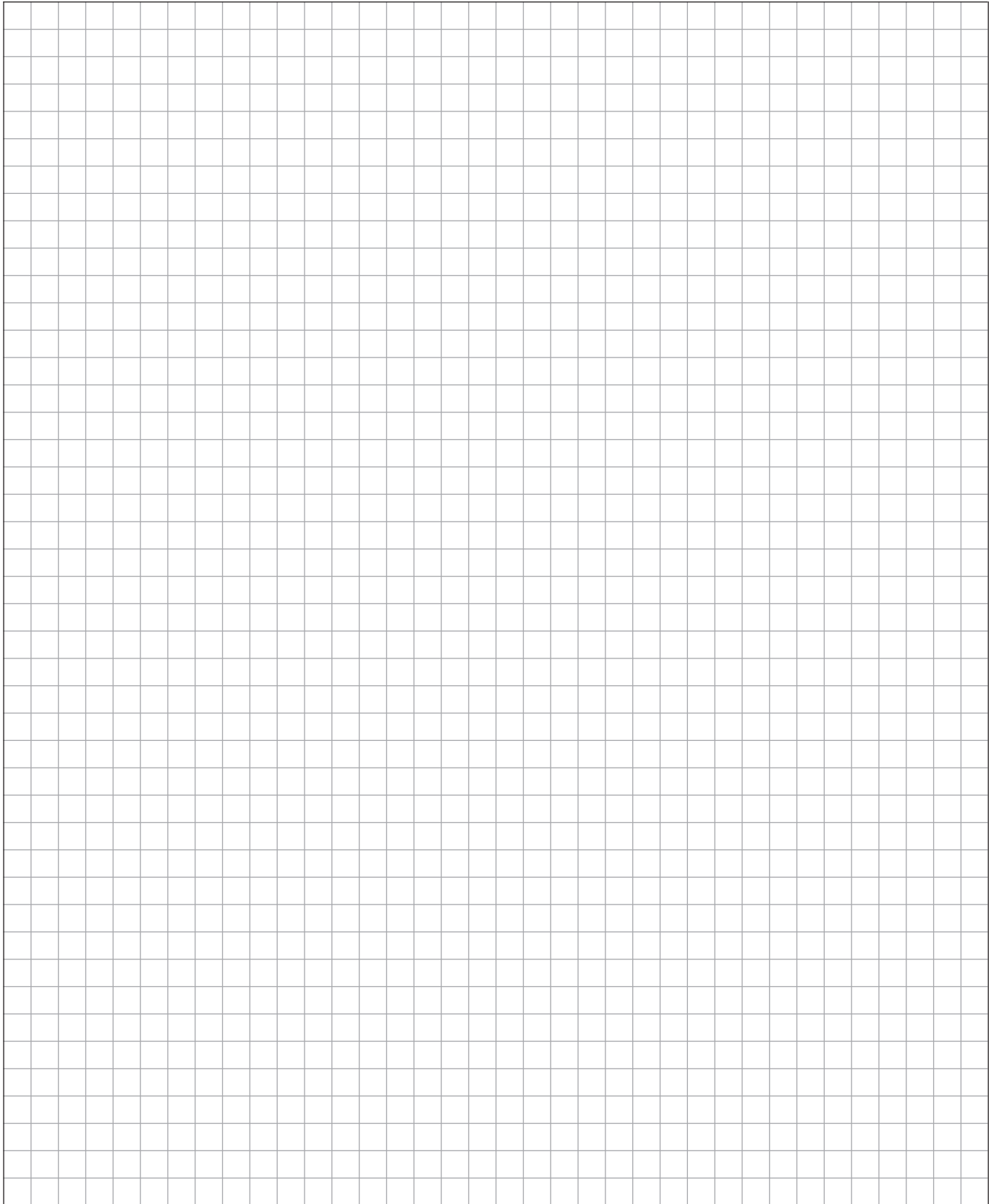

FLEXWELL® Safety Pipe

**Notes**

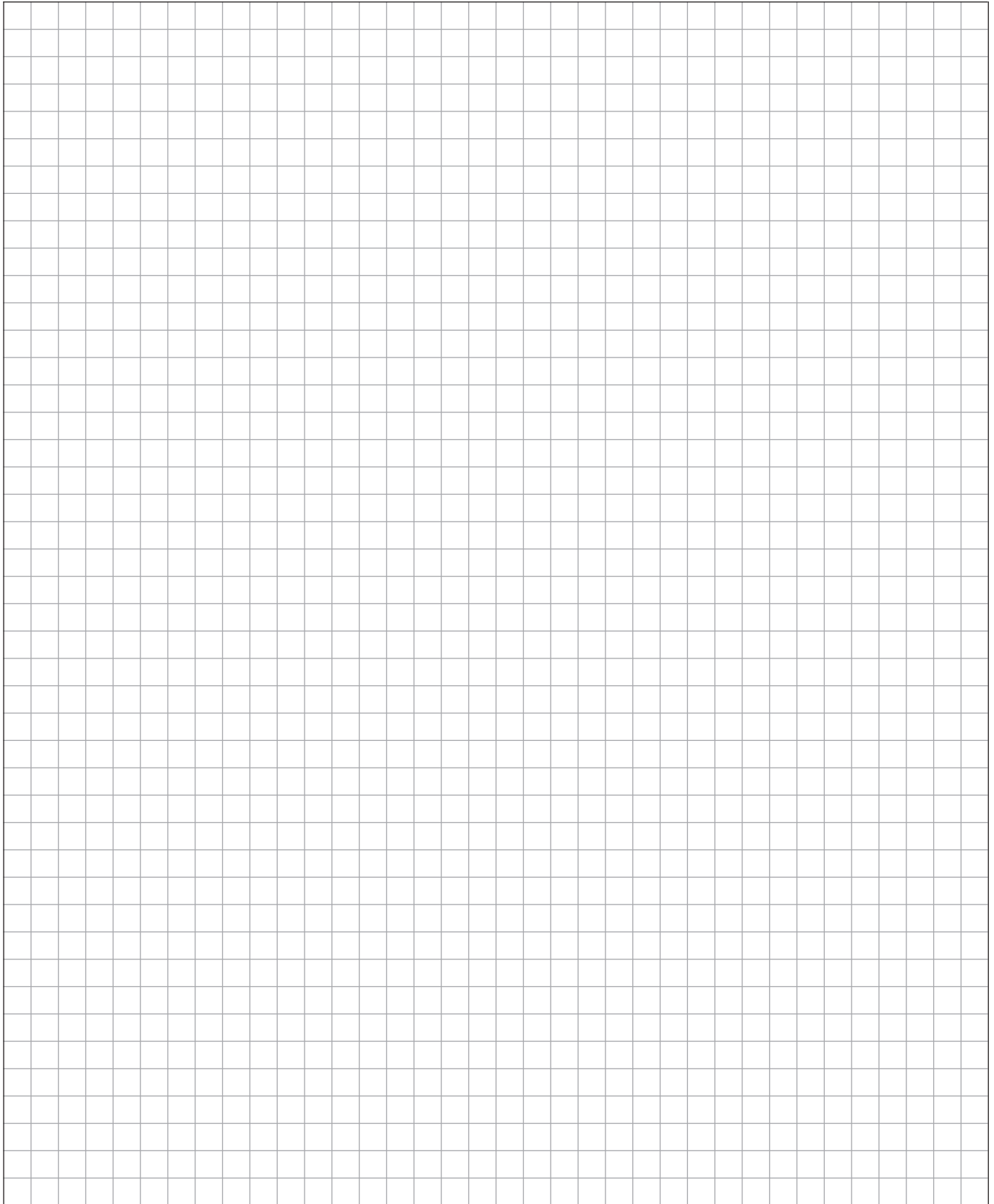

A BRUGG GROUP COMPANY

DE 05/22 / xxx ex. / 1016591



BRUGG Rohrsysteme GmbH · Adolf-Oesterheld-Straße 31 · 31515 Wunstorf · Germany · [brugg.de](http://brugg.de)