

Table of Contents

3.0	Table of Contents
3.1	System description
3.100	System description (general)
3.105	System description (data)
3.115	EIGERFLEX DN 20 - DN 100 with frost protection strip in the U-channel, carrier pipe Ø 25 - 110 mm
3.116	EIGERFLEX LONGLINE DN 32 - DN 125 with fixed-resistance heating tape, carrier pipe Ø 40 - 125 mm
3.2	Planning, design engineering
3.200	Pressure loss chart, DN 20 - DN 100 (SDR 11)
3.210	Heat loss in the buried-/installed above ground
3.3	Components
3.315	EIGERFLEX L-shell, dimension Ø 76 - 126 mm
3.316	EIGERFLEX Big-L-shell, dimension Ø 162 mm
3.320	Joint (PE-HD shrink sleeve), dimension Ø 76 - 162 mm
3.325	EIGERFLEX I-shell, dimension Ø 76 - 126 mm
3.326	EIGERFLEX Big-I-shell, dimension Ø 162 mm
3.330	EIGERFLEX T-shell, dimension Ø 76 - 126 mm
3.335	EIGERFLEX Big-T-shell, dimension Ø 162 mm
3.345	Insulation material, PUR-foam containers / PE-Isolation
3.350	PE-jointing methods 1, screwed connectors (external thread, weld end)
3.355	PE-jointing methods 1, screwed connectors (coupling, equal, 90° angle coupling)
3.360	PE-jointing methods 3, fusion-welded and alternative connections
3.365	End closure, shrink-type closure
3.370	Wall sealing ring, pipe warning tape
3.375	Building entry, wall opening/core bore
3.380	Building entry, core bores/cement pipe liners
3.4	Underground construction, installation
3.505	Trench dimensions
3.510	FSB connection technology, sleeve joint
3.515	FSB connection technology, T-piece
3.520	Connection to end of frost protection strip

System description

1. General

EIGERFLEX is Brugg Pipe Systems' protected name for flexible, pre-insulated water pipes featuring an integrated frost protection strip (FPC) or EIGERFLEX LONGLINE with fixed-resistance trace heaters for applications involving lengthy heating circuits. These pipe system are especially suitable for cold water and waste water pipes which can either be installed above ground or at depths with frost.

EIGERFLEX cold water pipes feature consist of a medium pipe produced from high-density polyethylene (PE100) as per standard DIN EN 12201. Polyethylene pressure pipes are the standard for drinking water and waste water systems, and also for the gas supply sector, and they are excellently suited to the areas of application just mentioned. The pipes are joined by means of standardised screwed connectors, mechanical pipe couplings, with normal commercial electro-welded fittings or by means of polyfusion welding technology.

The heat insulation consists of CFC-free flexible rigid polyurethane foam with excellent insulating properties. The bending capacity of flexible EIGERFLEX cold water pipes means that they can be adapted to all pipe routing conditions without problems. It is possible to pass over or under existing supply pipes, and obstacles are easily bypassed. With flexible EIGERFLEX cold water pipes, you can choose the shortest pipe route without having to consider classical pipe construction methods.

The self-limiting frost protection strip (FPC) has direct contact to the medium pipe within the heat trace channel and a power capacity of 18 W/m. EIGERFLEX cold water pipe is prefabricated as appropriate and supplied in the required lengths; it always offers the same performance, regardless of the quantities ordered. The maximum length of the heating circuit varies according to the cut-in temperature, which must be controlled by a thermostat.

The EIGERFLEX LONGLINE cold water pipe incorporates fixed-resistance trace heaters which allow heating circuit of up to 1,000 metres in length with one power supply. Depending on the specific project, the trace heater is defined according to the operating conditions and the required route length, and is controlled by means of power regulation during operation. These properties make it very easy to transport service water or wastewater in areas lacking infrastructure.

The desired length of flexible EIGERFLEX cold water pipes is delivered to site in continuous form, either in rings or on a cable drum. Thanks to the generous delivery lengths, pipes can be laid largely without connection points in the ground, so the width of the pipe trench can be considerably reduced. Substantial savings are possible because underground construction work is minimised and installation is fast as well as simple.

2. Range of applications

Max. continuous operating temperature T_{Bmax} :	-30 to +20 °C
Max. permitted operating pressure p:	max. 16 bar

System description

1. Medium pipe

Material: Polyethylene class PE100 with high density, to DIN EN 12201 / DIN 8074 / DIN 8075
 Life expectancy: 50 years at 20 °C (16 bar) resp. 40 °C (11.6 bar) to DIN 8074 (SF 1.25)
 Characteristics: Suitable for cold water and sewage/waste water pipes

PE medium pipe	Ref. temp. °C	Value	Test standard
Density	–	952 - 960 kg/m ³	DIN 53479
Heat conductivity	40 - 46	0.40 W/mK	DIN 52612
Ultimate tensile strength (tearing resistance)	20	32 N/mm ²	DIN 53455
Modulus of elasticity	20	1000 N/mm ²	DIN 53457
Linear expansion coefficient	20	1.8 · 10 ⁻⁴ 1/K	DIN 52328
Crystallite melting range	–	130 - 135 °C	–

2. Frost protection strip/Heating tape

Material:

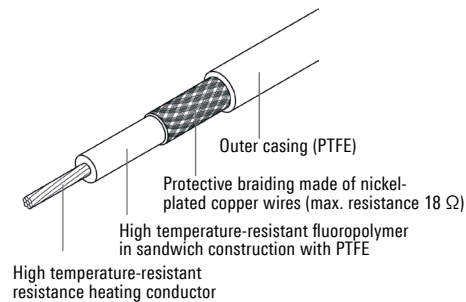
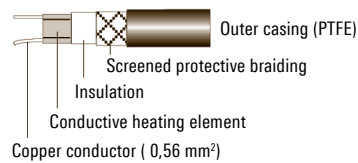

Type	EIGERFLEX	EIGERFLEX LONGLINE
Dimensions	25 - 110 mm	40 - 125 mm
Heating element	selfregulating	Résistance constante
Dimensions	Width 7.6 mm, Thickness 5.2 mm	up to max. Ø 7.0 mm
Minimum bending radius	20 mm	25 mm
Operating voltage	230 V AC 50 Hz	max. 500 V AC
Max. operating temperature powered	Continuous operation 65 °C, short periods 85 °C, to –30 °C	Continuous operation 90 °C
Max. heating circuit length:	102 m / 16 A at 10 °C 60 m / 10 A at 10 °C	max. 1000 m
Power delivery	18 W/m at 10 °C	max. 20 W/m
Control	Thermostat	Thermostat and Temperature limiter

To protect people and equipment, we basically specify a 30 mA residual current-operated device (FI).

3. Heat insulation

Material: CFC-free, 100% CO₂-driven polyurethane foam (PUR)

PUR-insulation	Ref. temperature °C	Value	Test standard
Density	–	> 50 kg/m ³	ISO 845
Heat conductivity	30	≤ 0.023 W/mK	EN 253 and ISO 8497
Closed cellular structure	–	≥ 88 %	EN 253
Water absorption after 24 hrs.	–	≤ 10 %	EN 15632-1

4. Enveloppe de protection

Material: Polyethylene of low density, PE-LLD, extruded seamless
 Purpose: Protection against mechanical effects and moisture

PE-LLD-protective casing	Ref. temperature °C	Value	Test standard
Density	–	918 - 922 kg/m ³	ISO 1183
Heat conductivity	–	0.33 W/mK	DIN 52612
Crystallite melting range	–	122 °C	ISO 11357-3

EIGERFLEX range

Dimensions DN 20 - DN 100 (with frost protection strip)

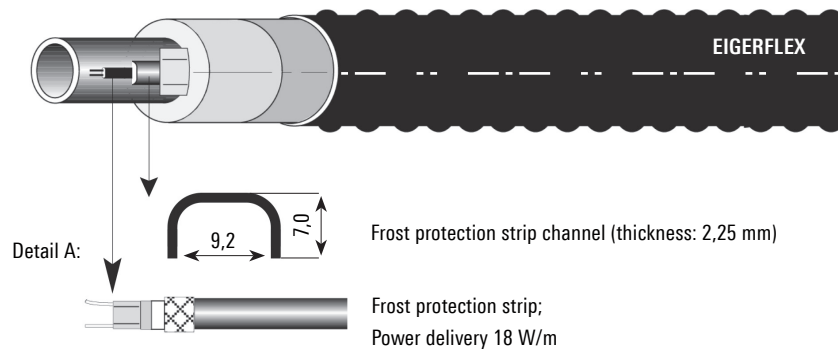
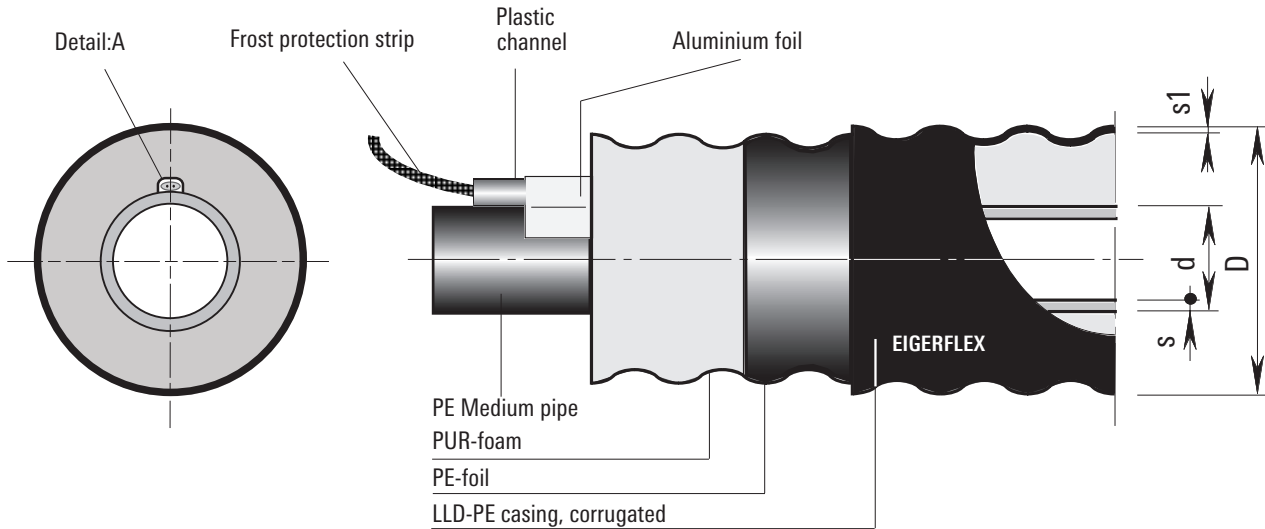

Dimensions DN 20 - DN 100

Type	DN	Inches	Medium pipe PE d x s mm	Outer casing D x s1 mm	Min. bending radius m	Medium pipe Volume l/m	Weight kg/m	max.delivery length* Coil length m
25/ 76	20	¾"	25 x 2.3	78 x 2.0	0.7	0.327	0.90	780
32/ 76	25	1"	32 x 2.9	78 x 2.0	0.8	0.539	1.20	780
40/ 91	32	1 ¼"	40 x 3.7	93 x 2.2	0.8	0.835	1.39	570
50/ 91	40	1 ½"	50 x 4.6	93 x 2.2	0.9	1.307	1.85	570
63/126	50	2"	63 x 5.8	128 x 2.7	1.0	2.091	2.60	305
75/126	65	2 ½"	75 x 6.8	128 x 2.7	1.0	2.961	2.75	305
90/162	80	3"	90 x 8.2	163 x 3.2	1.2	4.254	4.56	150
110/162	100	4"	110 x 10.0	163 x 3.2	1.2	6.362	5.69	150

* Supplies with partial lengths are possible

- other dimensions on request (> 500 m)
- larger or shorter lengths delivered on drums
- Ring dimensions:

Jumbo coil
Maxi coil

Outer diameter 2800 mm x 800 mm (width)
Outer diameter 2800 mm x 1200 mm (width)

EIGERFLEX LONGLINE range

Dimensions DN 32 - DN 125 (with fixed-resistance heating tape)

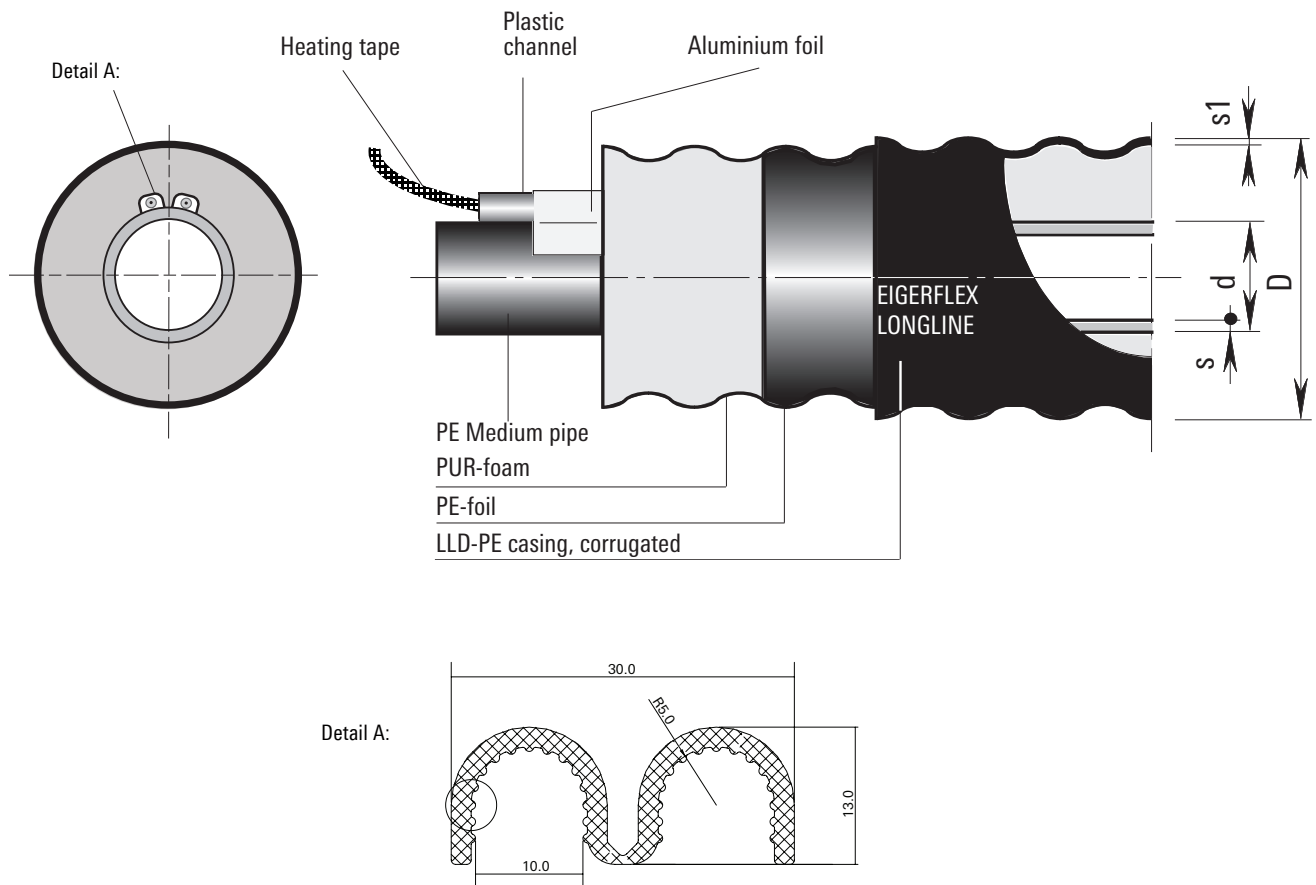

Dimensionen DN 32 - DN 125

Type	DN	Inches	Medium pipe PE d x s mm	Outer casing D x s1 mm	Min. Bending radius m	Medium pipe Volume l/m	Weight kg/m	max.delivery length* Coil length m
40/ 91	32	1 ¼"	40 x 3.7	93 x 2.2	0.8	0.835	1.39	570
50/ 91	40	1 ½"	50 x 4.6	93 x 2.2	0.9	1.307	1.85	570
63/126	50	2"	63 x 5.8	128 x 2.7	1.0	2.091	2.60	305
75/126	65	2 ½"	75 x 6.8	128 x 2.7	1.0	2.961	2.75	305
90/162	80	3"	90 x 8.2	163 x 3.2	1.2	4.254	4.56	305
110/162	100	4"	110 x 10.0	163 x 3.2	1.2	6.362	5.69	305
125/182	125	5"	125 x 11.4	183 x 3.3	1.3	8.200	7.80	90

EIGERFLEX LONGLINE is project-specific and not available from stock.

Pressure loss

DN 20 - DN 100 (SDR 11)

Water temperature 20 °C

Roughness $\epsilon = 0.01$ mm (PE100)

(1 mmWS = 9.81 Pa)

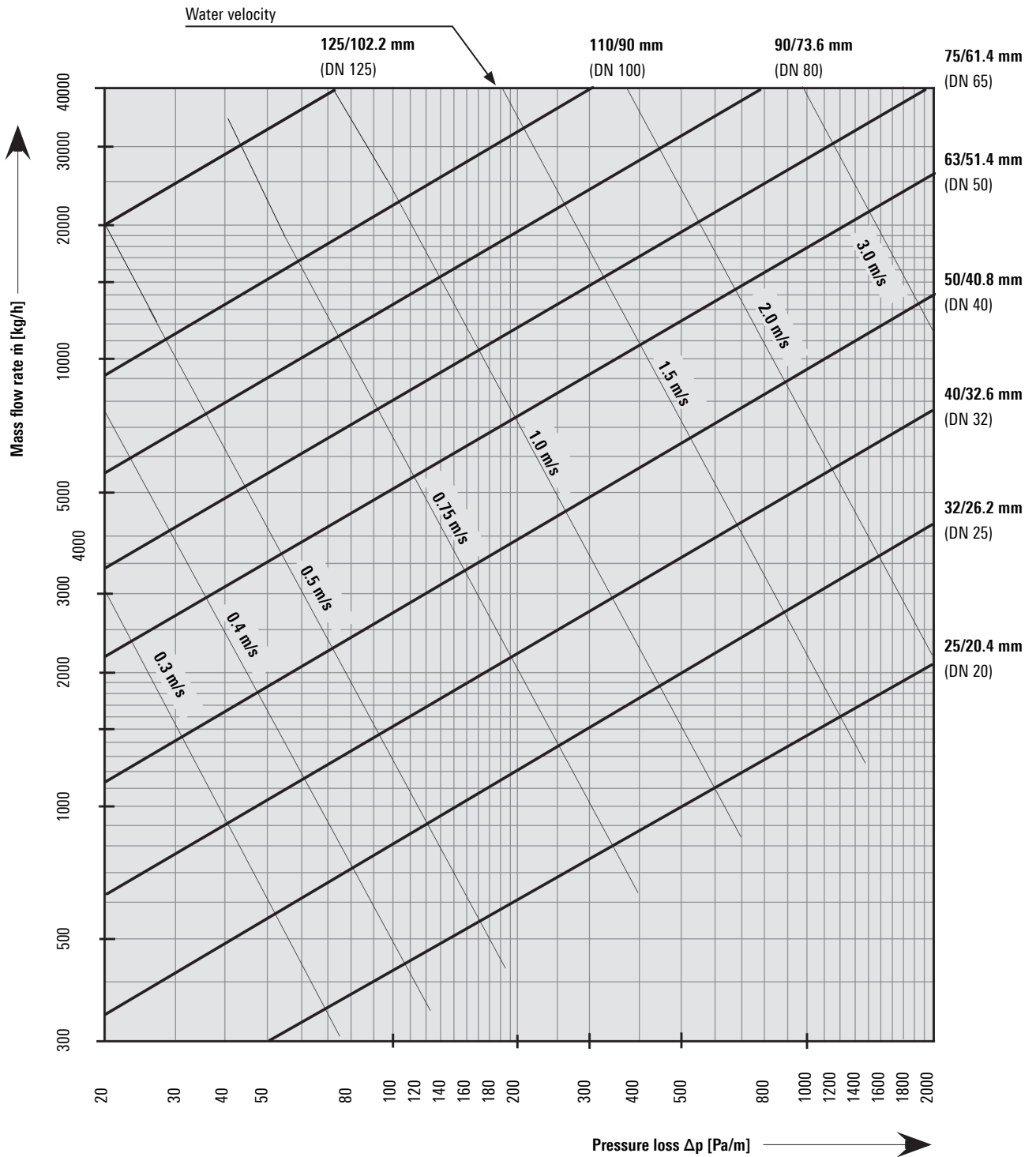

Heat loss

Heat losses at different external temperatures or surface temperatures of the casing pipe.

EIGERFLEX

The frost protection strip can no longer compensate for a heat loss of more than 14 W/m, and there is a **danger of freezing**.

EIGERFLEX LONGLINE

Die Dämmstärke sowie der elektrische Widerstand wird projektabhängig definiert.

For EIGERFLEX pipes **no minimal soil temperature** is required.

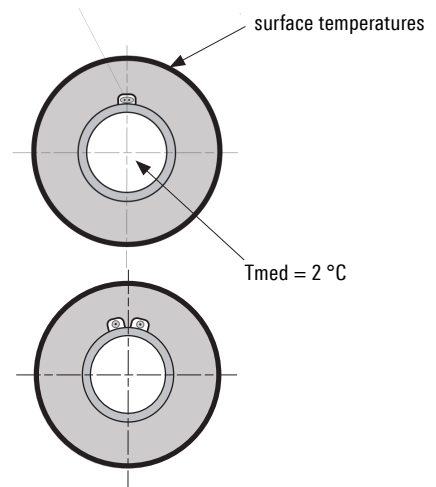

Heat loss figures for buried EIGERFLEX pipes

Heat losses q [W/m] for one UNO pipe

Dimension	U-value [W/mK]	Surface temperature [°C]				
		-5°	-10°	-15°	-20°	-25°
25/ 76	0.1265	0.9	1.5	2.2	2.8	3.4
32/ 76	0.1611	1.1	1.9	2.7	3.5	4.3
40/ 91	0.1685	1.2	2.0	2.9	3.7	4.5
50/ 91	0.2273	1.6	2.7	3.9	5.0	6.1
63/126	0.1982	1.4	2.4	3.4	4.4	5.4
75/126	0.2592	1.8	3.1	4.4	5.7	7.0
90/162	0.2318	1.6	2.8	3.9	5.1	6.3
110/162	0.3392	2.4	4.1	5.8	7.5	9.2
125/182	0.3385	2.4	4.1	5.8	7.4	9.1

The **minimal temperature** for above ground installation is **-30°C**.

Heat loss figures for EIGERFLEX pipes installed above ground

Heat losses q [W/m] for one UNO pipe

Dimension	U-value [W/mK]	Surface temperature [°C]				
		-5°	-10°	-15°	-20°	-25°
25/ 76	0.1326	1.0	1.6	2.3	3.0	3.7
32/ 76	0.1711	1.2	2.1	3.0	3.9	4.8
40/ 91	0.1798	1.3	2.2	3.2	4.1	5.0
50/ 91	0.2484	1.8	3.1	4.4	5.7	7.0
63/126	0.2137	1.5	2.6	3.7	4.8	5.9
75/126	0.2863	2.1	3.6	5.1	6.5	8.0
90/162	0.2528	1.8	3.1	4.4	5.7	7.0
110/162	0.3860	2.8	4.8	6.8	8.9	10.9
125/182	0.3990	2.8	4.8	6.8	8.8	10.8

Type of installation:

Cover above pipe:

Ground temperature:

Soil conductivity:

Medium temperature:

Conductivity of PUR foam:

Conductivity of PE pipe:

Conductivity of PE casing:

Ground installation

H = 0.80 m

T_E = Variable (see table)

λ_E = 1.0 W/mK

T_{med} = 2 °C

λ_{PUR} = 0.023 W/mK

λ_{HDPE} = 0.40 W/mK

λ_{LLDPE} = 0.33 W/mK

Type of installation:

Wind speed:

Open installation

BFT 10 whole gale (25.2 - 29 m/s)

EIGERFLEX L-shell

Dimension DN 20 - DN 65 (Ø 76 - 126 mm)

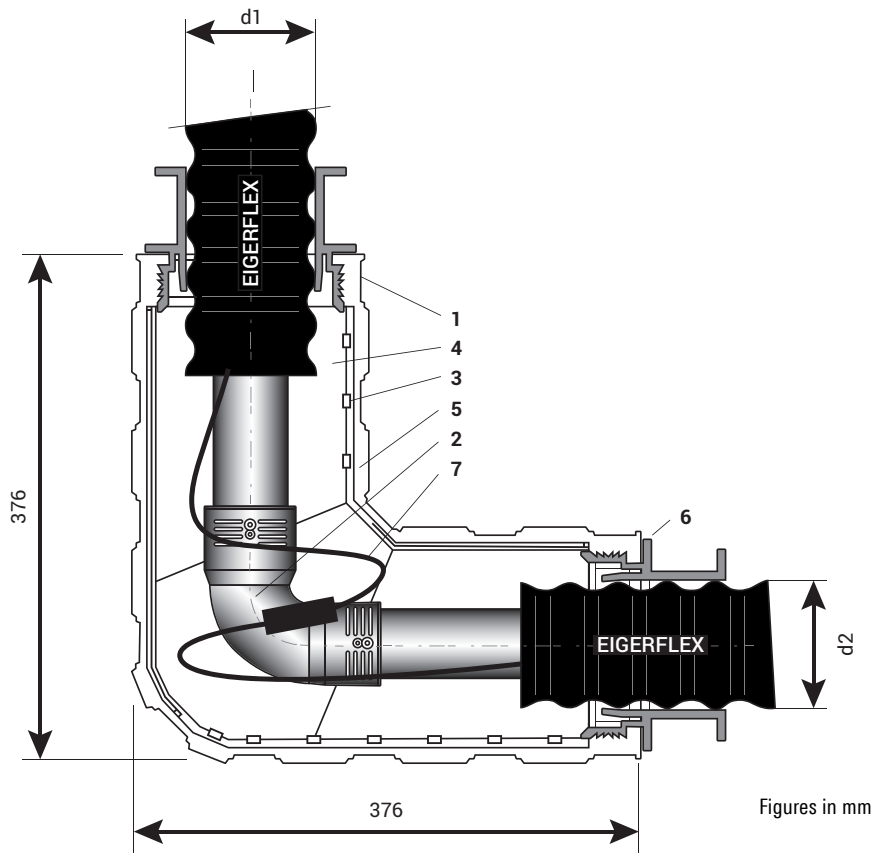

Figures in mm

EIGERFLEX L-shell

Outer casing Ø d1	Ø d2			
	76	91	111	126
76	x			
91		x		
111			x	
126				x

PE-jointing methods; see CPE 3.350 - 3.360

Structure of the half-shell

- 1 ABS-half-shells
- 2 Electro-fusion-joints; see CPE 3.360
- 3 Sealing clamps (14 pcs.)
- 4 Insulation material; see CPE 3.345
- 5 Glued surface
- 6 Reducer ring or sealing ring
- 7 Frost protection strip

Note: Install protected against climatic influences (UV radiation).

EIGERFLEX Big-L-shell

Dimension DN 80 - DN 100 (Ø 182 mm)

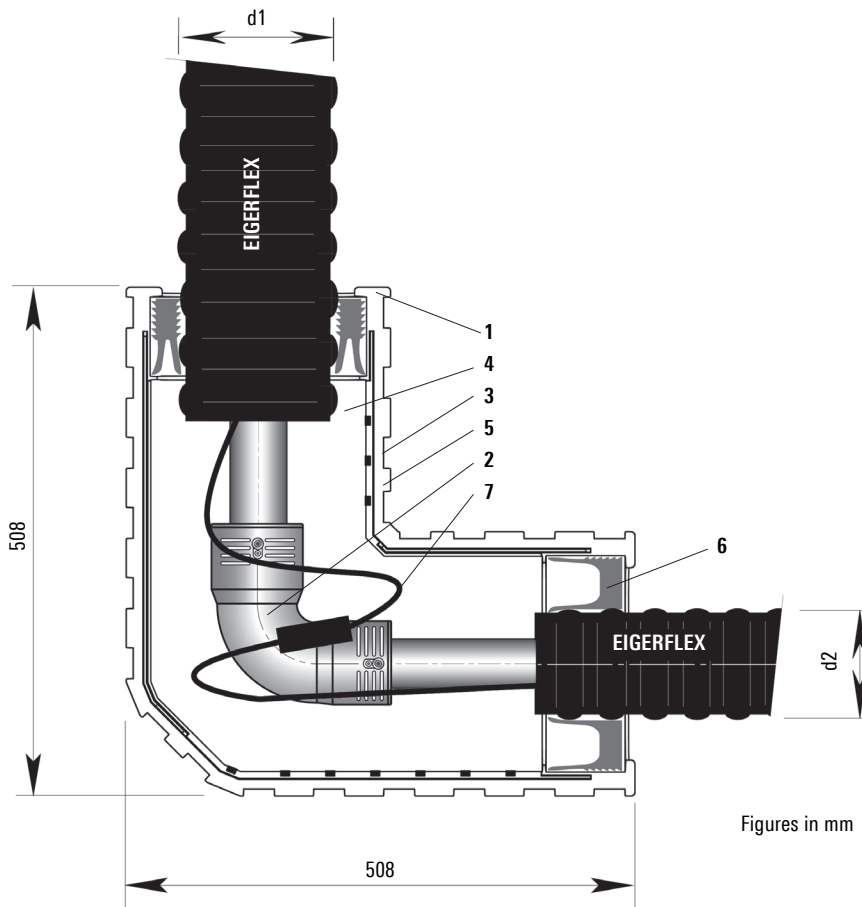

Figures in mm

EIGERFLEX Big-L-shell

Outer casing Ø d1	Ø d2					
	76	91	111	126	162	182
76						
91						
111						
126						
162						
182					x	

x

EIGERFLEX Big-shells are freely reducible from Ø 182 mm to Ø 76 mm
PE-jointing methods; see CPE 3.350 - 3.360

Structure of the half-shell

- 1 ABS half shells
- 2 PE-fusion welded joints; see CPE 3.360
- 3 Sealing clamps (22 pcs.)
- 4 Insulation material; see CPE 3.345
- 5 Glued surface
- 6 Reducer ring or sealing ring
- 7 Frost protection strip

Note: Install protected against climatic influences (UV radiation).

Joint using PE-HD shrink sleeve

Dimension \varnothing 76 - 182 mm

EIGERFLEX joints and reduction joints

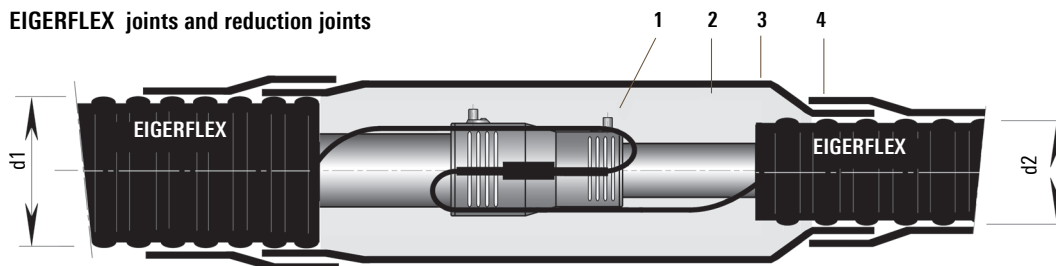

- 1 PE fusion welded joints; see CPE 3.360
- 2 Insulation material, PUR or PE; see CPE 3.345
- 3 Shrink sleeve pipe
- 4 Shrink hose

EIGERFLEX

\varnothing d2	76	91	126	162	182
\varnothing d1	76	x			
	91	x	x		
	126	x	x	x	
	162			x	x
	182				x

PE-jointing methods; see CPE 3.350 - 3.360

EIGERFLEX I-shell

Dimension DN 20 - DN 65 (Ø 76 - 126 mm)

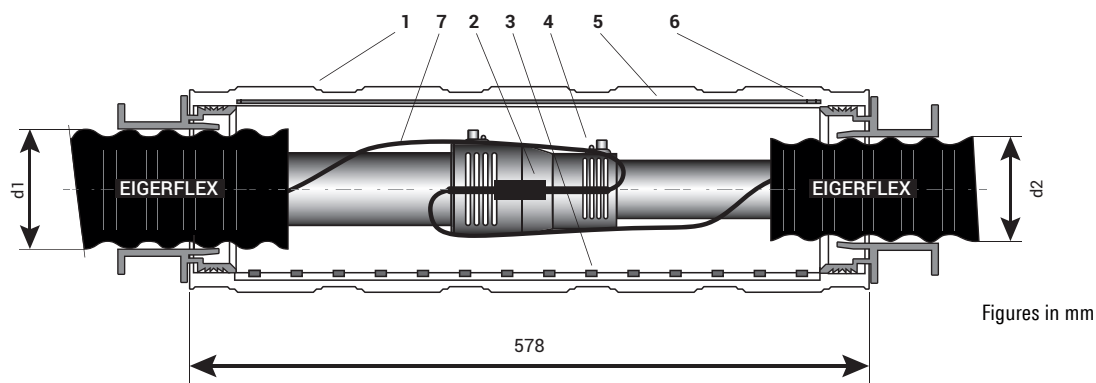

Figures in mm

- 1 ABS half-shells
- 2 PE fusion welded joints; see CPE 3.360
- 3 Sealing clamps (12 pcs.)
- 4 Insulation material; see CPE 3.345
- 5 Glued surface
- 6 Reducer ring or sealing ring
- 7 Frost protection strip

EIGERFLEX I-shell

Outer casing Ø d1	Ø d2			
	76	91	111	126
76	x			
91	x	x		
111	x	x	x	
126	x	x	x	x

PE-jointing methods; see CPE 3.350 - 3.360

Note: Install protected against climatic influences (UV radiation).

EIGERFLEX Big-I-shell

Dimension DN 80 - DN 100 (Ø 182 mm)

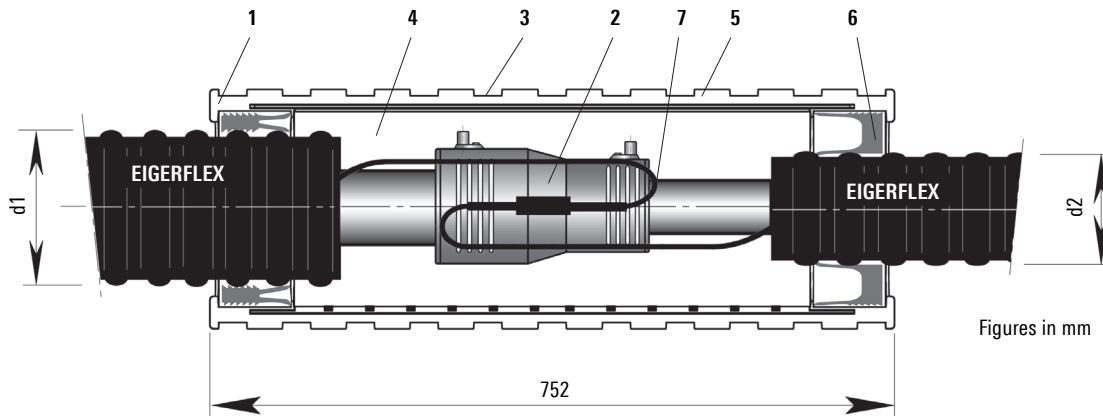

EIGERFLEX Big-I-shell

Outer casing Ø d1	Ø d2					
	76	91	111	126	162	182
76						
91						
111						
126				x		
162				x	x	
182						x

Structure of the half-shell

- 1 ABS half-shells
- 2 PE fusion welded joints; see CPE 3.360
- 3 Sealing clamps (22 pcs.)
- 4 Insulation material; see CPE 3.345
- 5 Glued surface
- 6 Reducer ring or sealing ring
- 7 Frost protection strip

EIGERFLEX Big-shells are freely reducible from Ø 182 mm to Ø 76 mm
PE-jointing methods; see CPE 3.350 - 3.360

Note: Install protected against climatic influences (UV radiation).

EIGERFLEX T-shell

Dimension DN 20 - DN 65 (Ø 76 - 126 mm)

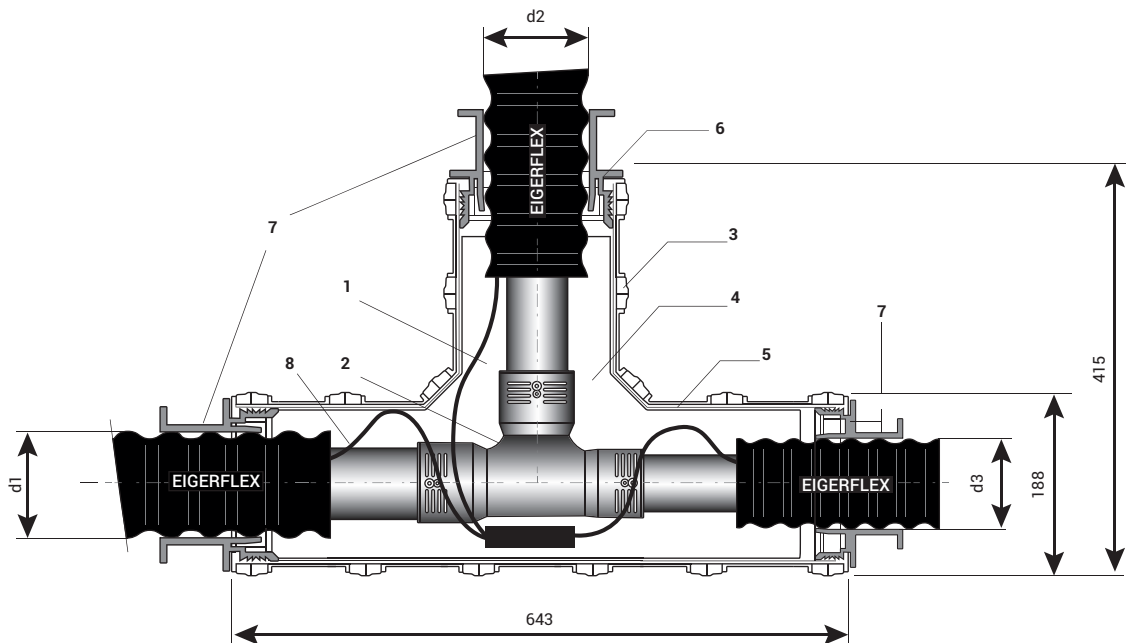

Figures in mm

EIGERFLEX T-shell

Outer casing Ø d1 - Ø d3	Branch, Ø d2			
	76	91	111	126
76 - 76	x	x	x	x
91 - 91	x	x	x	x
91 - 76	x	x	x	x
111 - 111	x	x	x	x
111 - 91	x	x	x	x
111 - 76	x	x	x	x
126 - 126	x	x	x	x
126 - 111	x	x	x	x
126 - 91	x	x	x	x
126 - 76	x	x	x	x

PE jointing methods; see CPE 3.350 - 3.360

Note: Install protected against climatic influences (UV radiation).

Structure of the half-shell

- 1 ABS half-shells
- 2 PE T-piece; see CPE 3.360
- 3 Sealing clamps (16 pcs.)
- 4 Insulation material; see CPE 3.345
- 5 Glued surface
- 6 Reducer ring or sealing ring
- 7 Frost protection strip

EIGERFLEX Big-T-shell

Dimension DN 80 - DN 100 (Ø 182 mm)

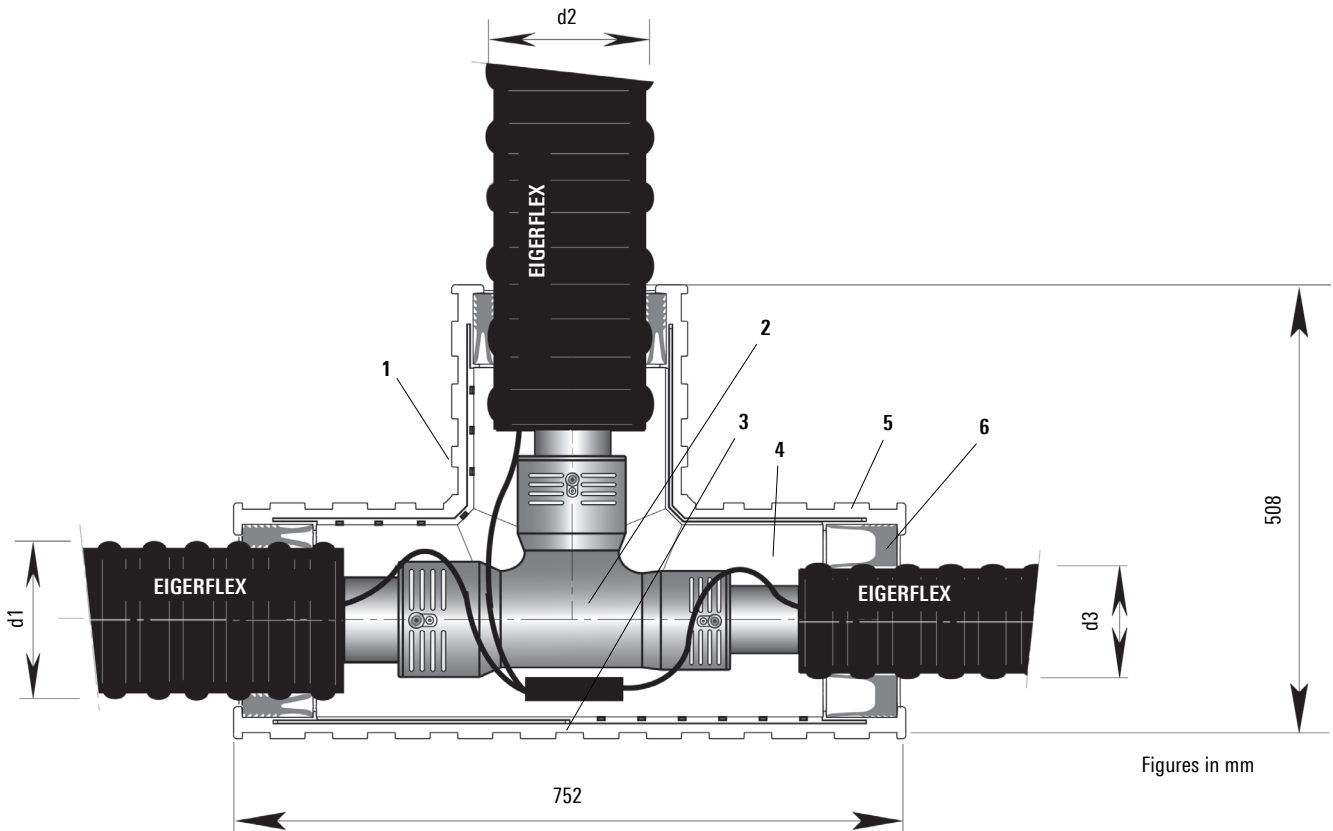

EIGERFLEX Big-T-shell

Outer casing Ø d1 - Ø d3	Branch, Ø d2					
	76	91	111	126	162	182
162 - 162	x	x	x	x	x	x
162 - 126	x	x	x	x	x	x
162 - 111	x	x	x	x	x	x
162 - 91	x	x	x	x	x	x
162 - 76	x	x	x	x	x	x
182 - 182	x	x	x	x	x	x
182 - 162	x	x	x	x	x	x
182 - 126	x	x	x	x	x	x
182 - 111	x	x	x	x	x	x
182 - 91	x	x	x	x	x	x
182 - 76	x	x	x	x	x	x

EIGERFLEX Big-shells are freely reducible from Ø 182 mm to Ø 76 mm
PE jointing methods; see CPE 3.350 - 3.360

Note: Install protected against climatic influences (UV radiation).

Structure of the half-shell

- 1 ABS half-shells
- 2 PE T-piece; see CPE 3.360
- 3 Sealing clamps (27 pcs.)
- 4 Insulation material; see CPE 3.345
- 5 Glued surface
- 6 Reducer ring or sealing ring
- 7 Frost protection strip

Insulation material

PUR foam containers, PE-Insulation

PUR foam containers

CFC-free PUR foam in plastic bottles



Safety regulations

Protective goggles and gloves must be worn during the foaming process.

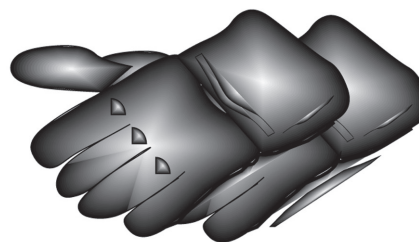

Synthetic gloves



Protective goggles

Shrink joints

Polyethylene foam tube

Extruded pipe insulation made of closed-cell polyethylene, excellent for insulating EIGERFLEX shrink joints. Various thicknesses of insulation are available for the most common pipe diameters.

The insulation material (thickness and length) is supplied for the relevant joint types. The insulation must be fitted precisely into the joints on site.

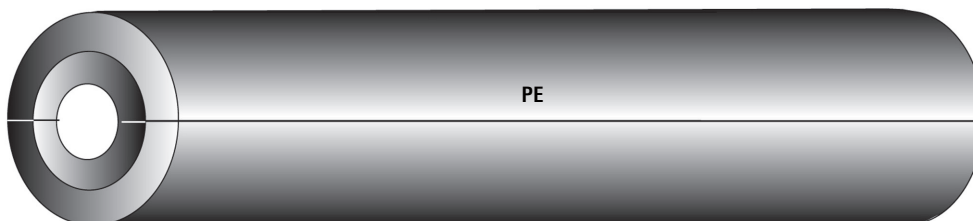

PE jointing methods

Screwed connectors (outer thread, weld end)

Connection with outer thread

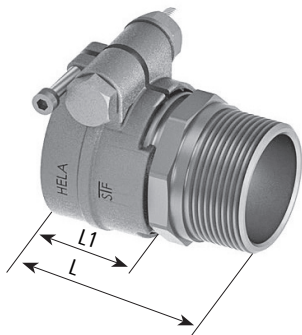

Coldwater, 6 bar

Material: brass

PE-pipe mm	Screw connection mm	
25 x 2.3	25 x 2.3-3/4"	61/26
32 x 2.9	32 x 2.9-1"	68/29
40 x 3.7	40 x 3.7-1 1/4"	77/36
50 x 4.6	50 x 4.6-1 1/2"	79/36
63 x 5.7	63 x 5.7-2"	97/46
75 x 6.8	75 x 6.8-2 1/2"	107/53
75 x 10.3	75 x 10.3-2 1/2"	101/53
110 x 10.0	110 x 10.0-4"	135/70
125 x 11.4	125 x 11.4-5"	144/69

Connection with welding end

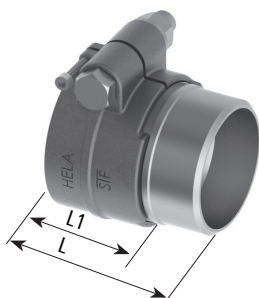

Coldwater, 6 bar

Material: brass

PE-pipe mm	Welding end mm	L/L1 mm
25 x 2.3	26.9 x 2.3	61/26
32 x 2.9	33.7 x 2.6	63/29
40 x 3.7	42.4 x 2.6	75/36
50 x 4.6	48.3 x 2.6	84/36
63 x 5.7	60.3 x 2.9	88/46
75 x 6.8	76.1 x 2.9	101/53
90 x 8.2	88.9 x 3.2	108/58
110 x 10.0	114.3 x 3.6	114/70
125 x 11.4	114.3 x 3.6	120/69

Welding ends are not suitable for drinking water applications.

PE jointing methods

Coupling, equal, 90° angle coupling

Coupling, equal

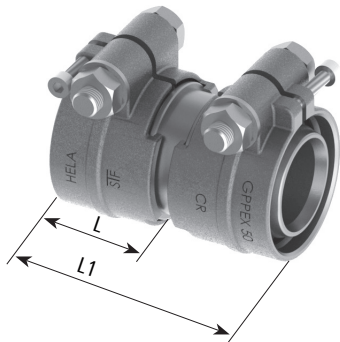

Coldwater, 6 bar

Material: brass

PE-pipe mm	Coupling mm	L/L1 mm
25 x 2.3	25 x 2.3	68/26
32 x 2.9	32 x 2.9	75/29
40 x 3.7	40 x 3.7	90/36
50 x 4.6	50 x 4.6	90/36
63 x 5.7	63 x 5.7	110/46
63 x 8.7	63 x 8.7	110/46
90 x 8.2	90 x 8.2	144/58
110 x 10.0	110 x 10.0	168/70
125 x 11.4	125 x 11.4	167/69

Couplings, reduced (soldered) can be supplied on request.

90° angle coupling



Coldwater, 6 bar

Material: brass soldered

PE-pipe mm	on PEX-pipe mm
25 x 2.3	25 x 2.3
32 x 2.9	32 x 2.9
40 x 3.7	40 x 3.7
50 x 4.6	50 x 4.6
63 x 5.7	63 x 5.7
75 x 6.8	75 x 6.8
90 x 8.2	90 x 8.2
110 x 10.0	110 x 10.0
125 x 11.4	125 x 11.4

T-pieces (soldered) can be supplied on request.

PE jointing methods

Fusion welded and alternative joints

PE100 electro fusion-welded fittings

SDR 11/SDR 17

Sleeves

Ø 25 - 125 mm



Reduction sleeves

Ø 25 - 125 mm



Angle piece, 90° equal

Ø 25 - 75 mm



Angle piece, 90° equal (without fusion joint)

Ø 90 - 125 mm



T-piece, equal/reduced

Ø 25 - 125 mm



T-piece, equal/reduced (without fusion joint)

Ø 25 - 125 mm



(Source: Georg Fischer Rohrleitungssysteme AG)

Butt-fusion

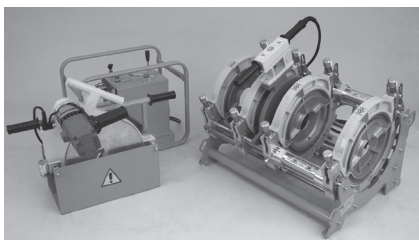

(Source: PF-Schweisstechnologie GmbH)

All jointing methods listed on this sheet are available on request.

End closure

Shrink-on closure

Shrink-on closure

EIGERFLEX shrink-on closures protect the PUR insulation on the front of the EIGERFLEX pipes against splashing water in buildings and shafts. **Important:** in contact with water (flooding), the shrink-on closure is not necessarily watertight! The shrink-on closure also stops gas escaping from the PUR insulation.

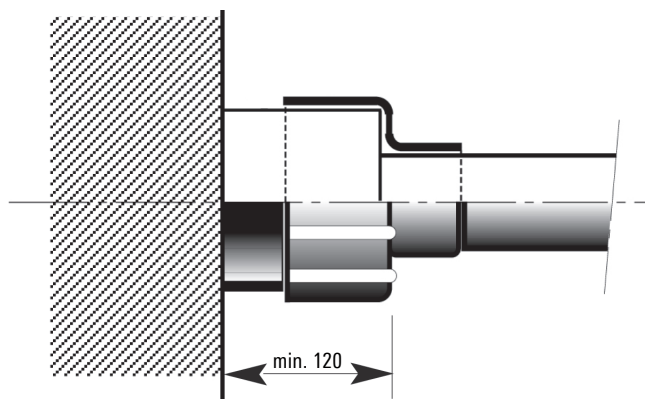

Important fitting note:

EIGERFLEX shrink-on closures must be pushed onto the end of the EIGERFLEX pipes before welding the inner pipes and must be protected against the action of heat during welding.

Material:

Heat-shrunk, cross-linked polyolefin. Coated with sealing adhesive

Wall sealing ring

Pipe warning tape

Wall sealing ring

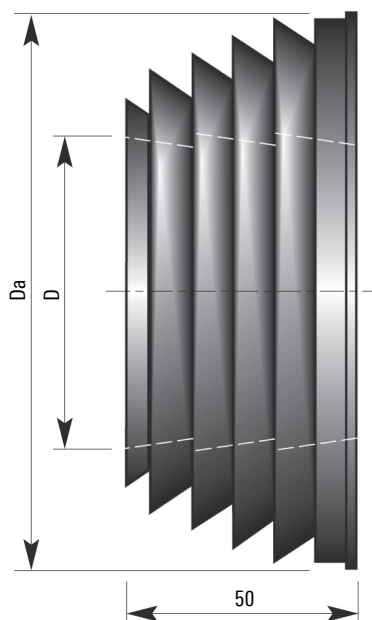

EIGERFLEX

Type CPE	Da
25/ 76	118
32/ 91	133
40/ 91	133
50/111	153
63/126	168
75/126	168
90/162	203
110/162	203
125/182	223

Pipe warning tape

- To be laid in the ground
- Standard roll length: 250 m
- Installation depth: see sheet CPE 3.505

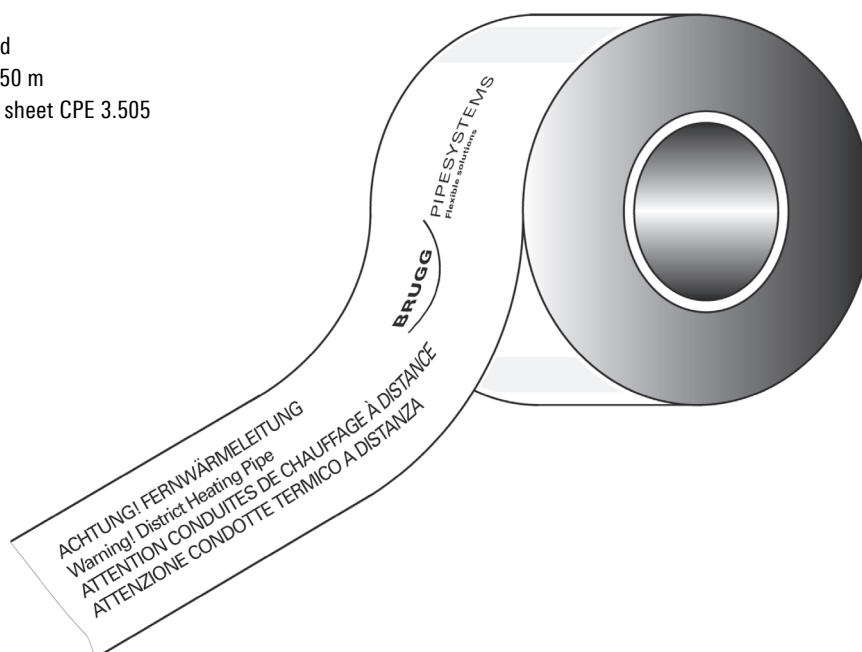

Building entry

Wall opening

Wall leadthrough

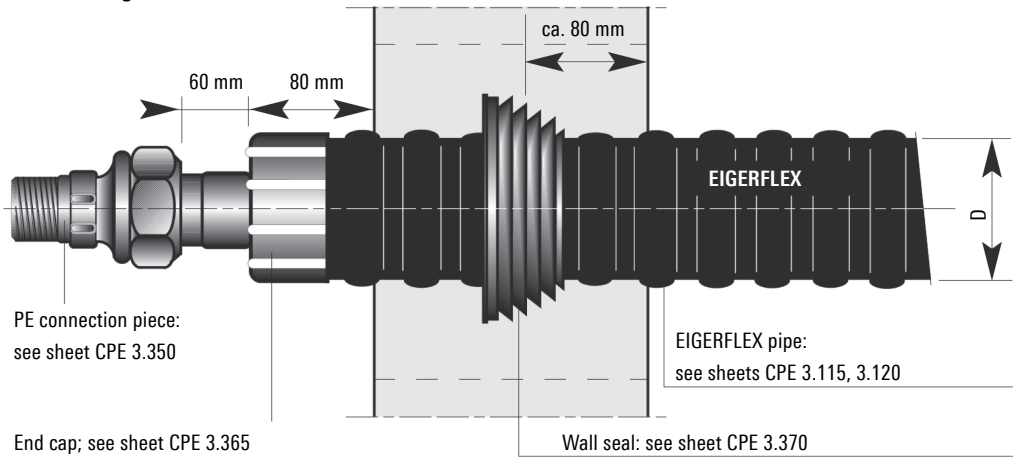

Wall opening

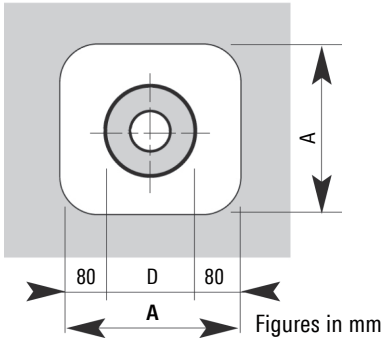

Outer casing Ø D mm	A mm
78	250
93	250
113	300
128	300
163	350
183	380

Core bores

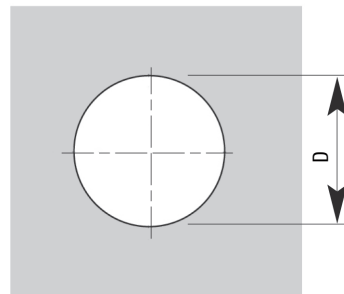

Outer casing Ø D mm	D mm
78	180
93	200
113	220
128	240
163	280
183	280

Building entry

Core bores/cement pipe liners

Wall leadthrough

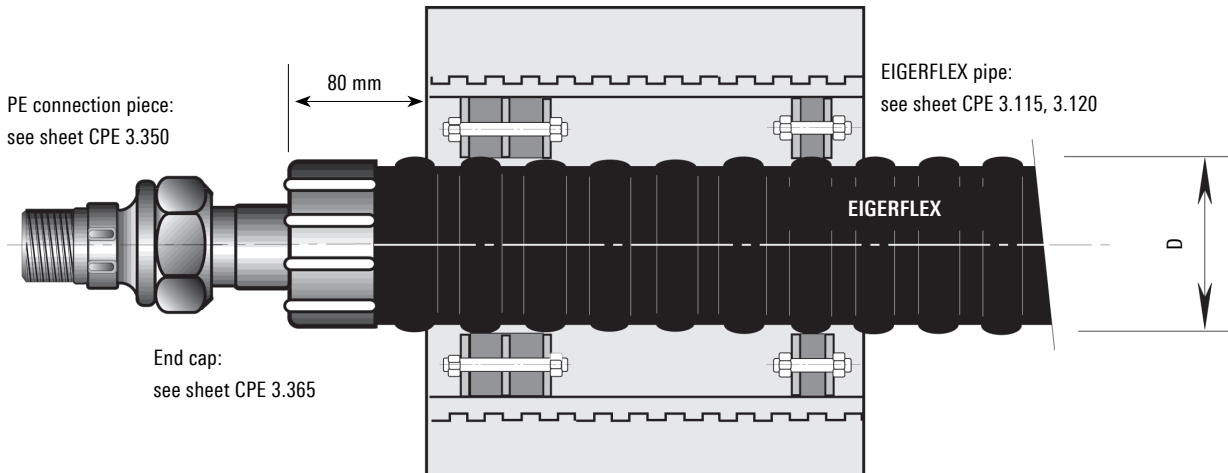

Core bores

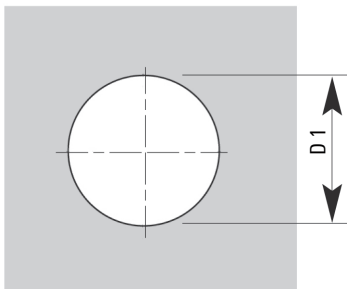

Outer casing Ø D mm	D1 mm
76	150
91	150
111	200
126	200
162	250
182	250

Core bores

Perfect bores are required for installation. As hairline cracks may be present in the concrete or result from drilling, it is advisable to seal the entire length of the borehole wall with suitable sealant (such as AQUAGARD).

Tightness can only be guaranteed if this recommendation is followed.

Key

- 1 EIGERFLEX
- 2 Sealing set, single-seal, width 1 x 40 mm, Shore hardness D35
- 3 Sealing set, double-seal*, width 2 x 40 mm, Shore hardness D35
- 4 Liner pipe: made of fiber cement or coated core bore

* Suitable for pressure from water up to 0.5 bar

Trench dimensions

Trench profile, 1 CPE pipe

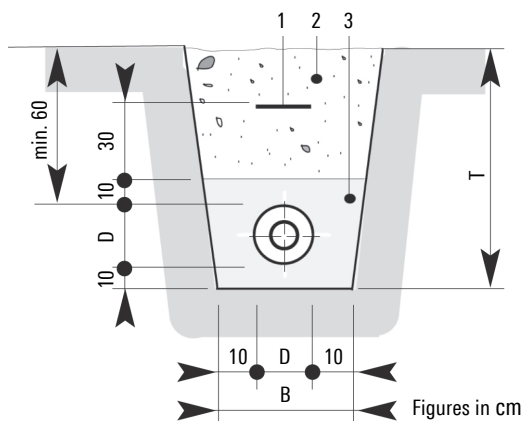

- 1 Pipe warning tape; see sheet CPE 3.370
- 2 Excavated material
- 3 Sand, washed, max. grain size 8 mm

Casing pipe Ø D mm	Width B cm	Depth T cm	Minimum Bending radius m
78	25	80	0.7
93	30	80	0.8
113	30	85	0.9
128	35	85	1.0
163	35	90	1.2
183	38	95	1.4

Installation depth:
 max. installation depth: 2.6 m
 Our approval is required for installation at greater depths.

SLW 30 \triangleq 300 kN total load as per DIN 1072; if subject to higher traffic loads (e.g. SLW 60), a load-distributing superstructure as per RSt075 is required.

With no traffic load, the minimum trench depth T can be reduced by 40 cm.

FSB connection technology

Sleeve joint EIGERFLEX

1. Planning

$L \leq 100$ m
Continuous joint

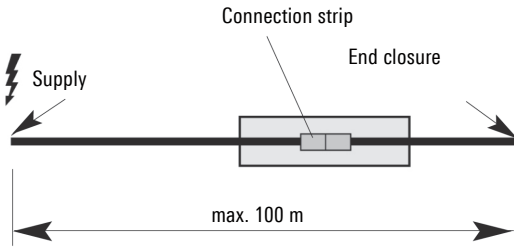

$L > 100$ m
Separation

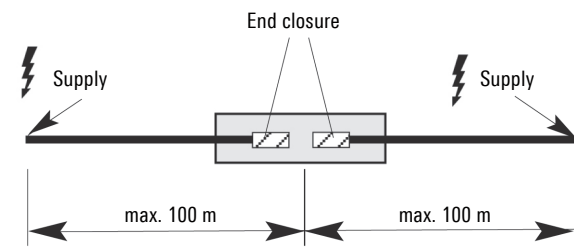

2. Preparation

Figure 1

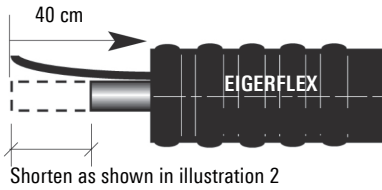
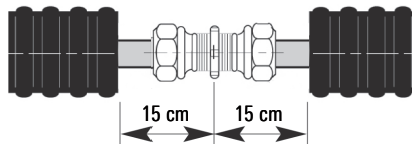

Figure 2



Remove 40 cm of insulation at the ends and carefully expose the strip. Then shorten the inner pipe to length as shown in illustration 2.

3. Sleeve joint

Continuous joint $L \leq 100$ m

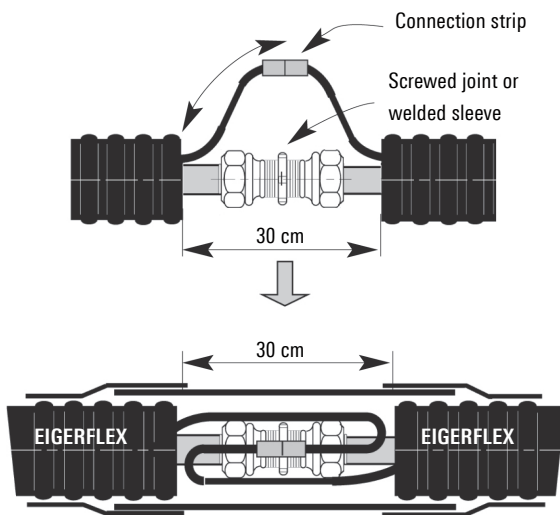

Separation
 $L > 100$ m

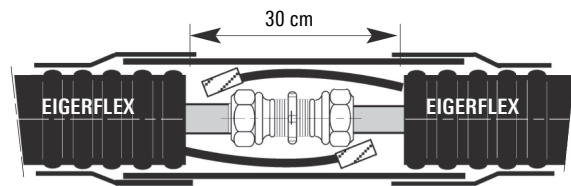

Protect heating strip against moisture

Connect the cables according to the installation instructions

FSB connection technology

T-Piece EIGERFLEX

1. Planning

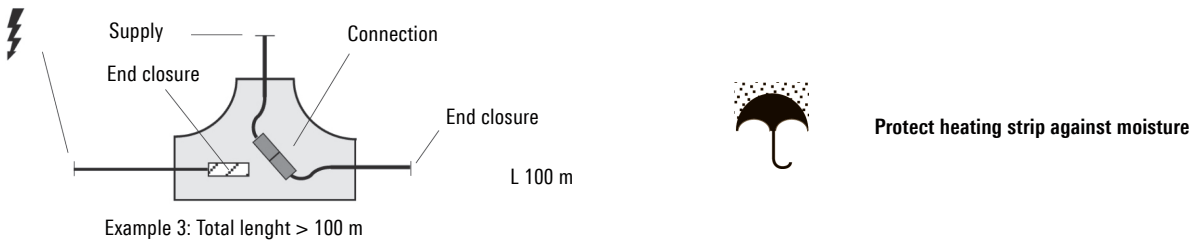
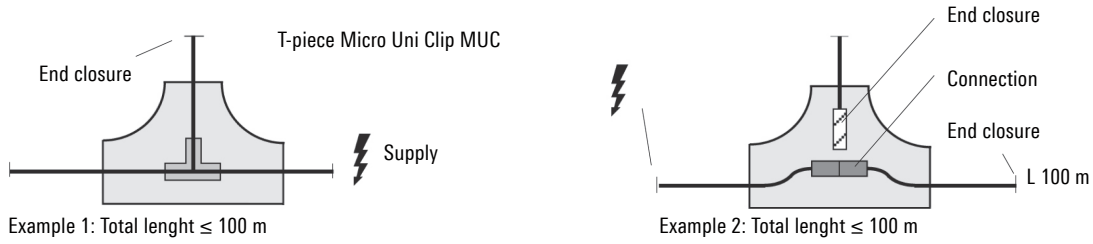

Make sure that the sum of the connected pipes is not more than 100 m.

2. Preparation

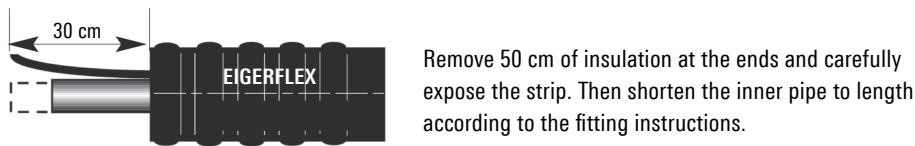

3. Fitting T-piece with T-junction

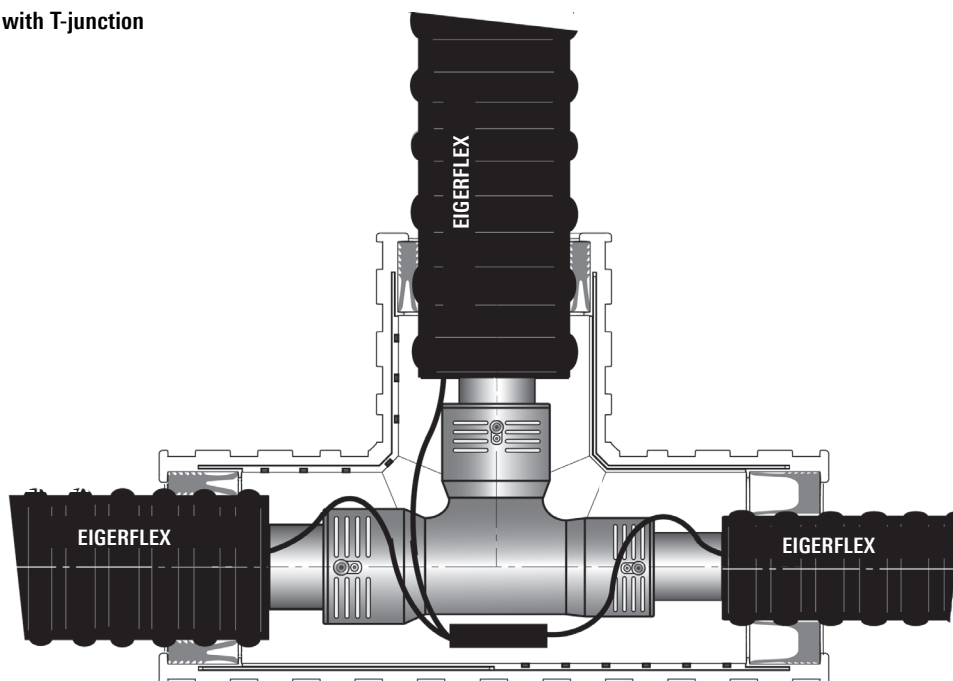

Connection and end

Frost protection strip EIGERFLEX

1. Technical data

Frost protection strip: Max. heating circuit length based on switch-on temperature of 10 °C: 16 A max. 100 m
10 A max. 60 m

Regulation: Thermostat UTR15

Adjustment range: -5 °C to +15 °C
pipe contact thermostat

2. Preparation

Remove 35-40 cm of insulation at the ends and carefully expose the strip. Then shorten the inner pipe to length according to the fitting instructions.

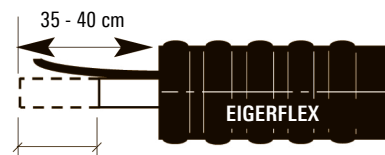

Shorten as described in fitting instructions

3. Installation procedure

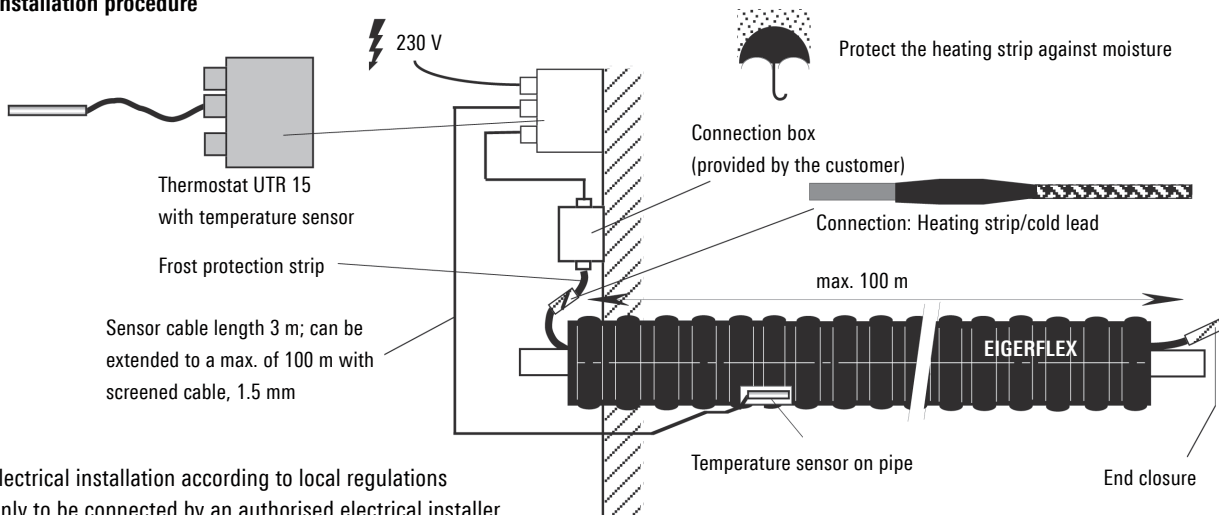

- Electrical installation according to local regulations
- Only to be connected by an authorised electrical installer
- 30 mA residual current-operated device (FI)-required by regulations!
- Automatic fuse, C-characteristic

4. Installing the temperature sensor on the pipe

The temperature sensor has to be installed on the medium pipe opposite the heating strip. It must be fitted at the coldest point on the pipe (outside the building). For this purpose, cut open a 10x7 cm area of the outer casing and peel back, cut out 10x7cm foam, and fix the temperature sensor on the inner pipe with adhesive tape. Fill the hole with the insulating material that is provided: apply filling adhesive S1113 below and above the temperature sensor cable (see sketch), seal with shrinkdown tube.

